

MODULAR PDRacer

A more portable version of the famous Puddle Duck Racer.

MARCH
2011

32 Pages

After much deliberation, I have decided to provide a new version of the Puddle Duck Racer for those that have requested a more portable configuration. I have submitted the plans to David "Shorty" Routh, the PDR originator, and received his approval for their use.

The Modular PDR is a three unit nesting version, that will fit in all Trucks, SUV's and some autos. No trailer required. Nested dimensions are 48" wide by 54" long and about 2 feet high.

The design conforms to the original PDR in hull shape and size, so that it can be used in regulation sailing events.

This design has an obvious advantage; No trailer is required. It also has a disadvantage, occupant space is limited due to the modular design. All other design options remain the same.

As with the original PDR, these are just hull assembly drawings. The sail rig setup is the builders option, as is the rudder, leeboards and any of the other accessories the builder wishes to add.

As the PDRacer plans are free, it is suggested you download them from the Puddle Duck website for review and reference.

www.PDRacer.com

Good luck with your project.

Ken Simpson, Designer

To obtain your free hull registration number, see the PDRacer.com website for details.

I also suggest you purchase a HIN Chunk Plate to support the class that we all enjoy.

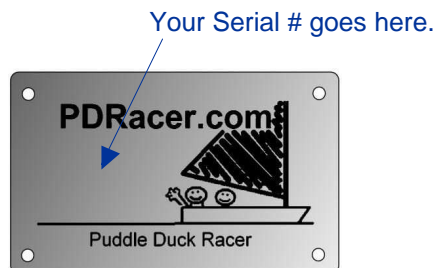

www.PortableBoatPlans.com

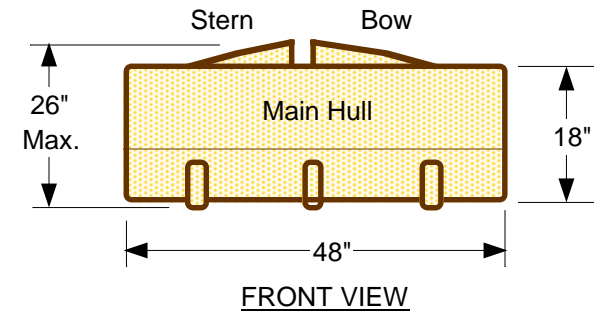

- NESTED VIEWS -

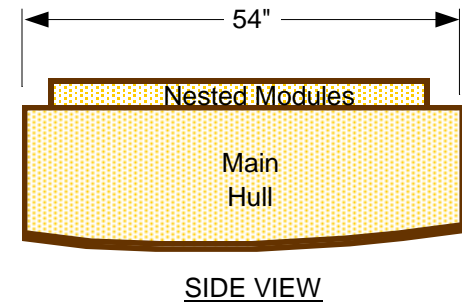

General Notes

The design of a **Nesting PDR** is a direct response to many requests by *PortableBoatPlans.com* viewers. The drawings have been reviewed, and approved, by David "Shorty" Routh. the PDR originator. It includes the standard beam, freeboard, air cells, and construction methods. It is lightweight, sturdy, easy to build, very portable and utilizes the standard sail platform.

The hull is strong and yet lightweight, and uses traditional methods of panel assembly , This provides for a durable, yet truly portable finished boat, and the building process is easily mastered by the home handyman and amateur boat builder.

As a result, only hand tools, a jig-saw, a power drill and a large carpenters square is all that will be required throughout the assembly process.

Be selective in your choice of materials. Use plywood that is preferably exterior rated. Marine or Luan Plywood may not be available, so the use of 1/4" ACX grade is suggested, but be choosy .

It is important to note, the final choice of materials is the sole decision of the builder. We have made specific building recommendations, but if the builder has previous experience with different methods and materials, that is their choice, and we respect that decision.

Certainly, minor changes in design are encouraged, to provide a 'custom' boat to satisfy a builders specific needs. We do not make changes to the drawings. This would be up to the individual builder, and their responsibility. Also, it is very important that none of the basic design parameters be drastically modified, as this may adversely affect overall boat safety or performance.

Seating choice is also up to the builder.

It should also be noted that the hull modules can be glued and screwed together, for those that do not have limitations of storage or transportation.

The hull exterior can also be completely fibreglassed for durability, allowing yet thinner and lighter (4 or 5 mm) plywood hull building material .

Any questions or comments regarding the construction and/or design of this project will be responded to in a timely fashion.

Thank you for your interest and purchasing these plans, and good luck with your project.

And don't forget to visit www.PortableBoatPlans.Com for new designs and updates.

Happy Boating !

Ken Simpson , Designer

www.PortableBoatPlans.com

This is an experimental design drawn up by an untrained amateur. The Designer accpets no liability for any loss or damage sustained during construction or use. Builders may use these plans to construct small numbers of boats freely for their own use. Commercial manufacturers must ask the designer to negotiate permission.

MODULAR PDRacer

HULL DESIGN LAYOUT

Mar 2011

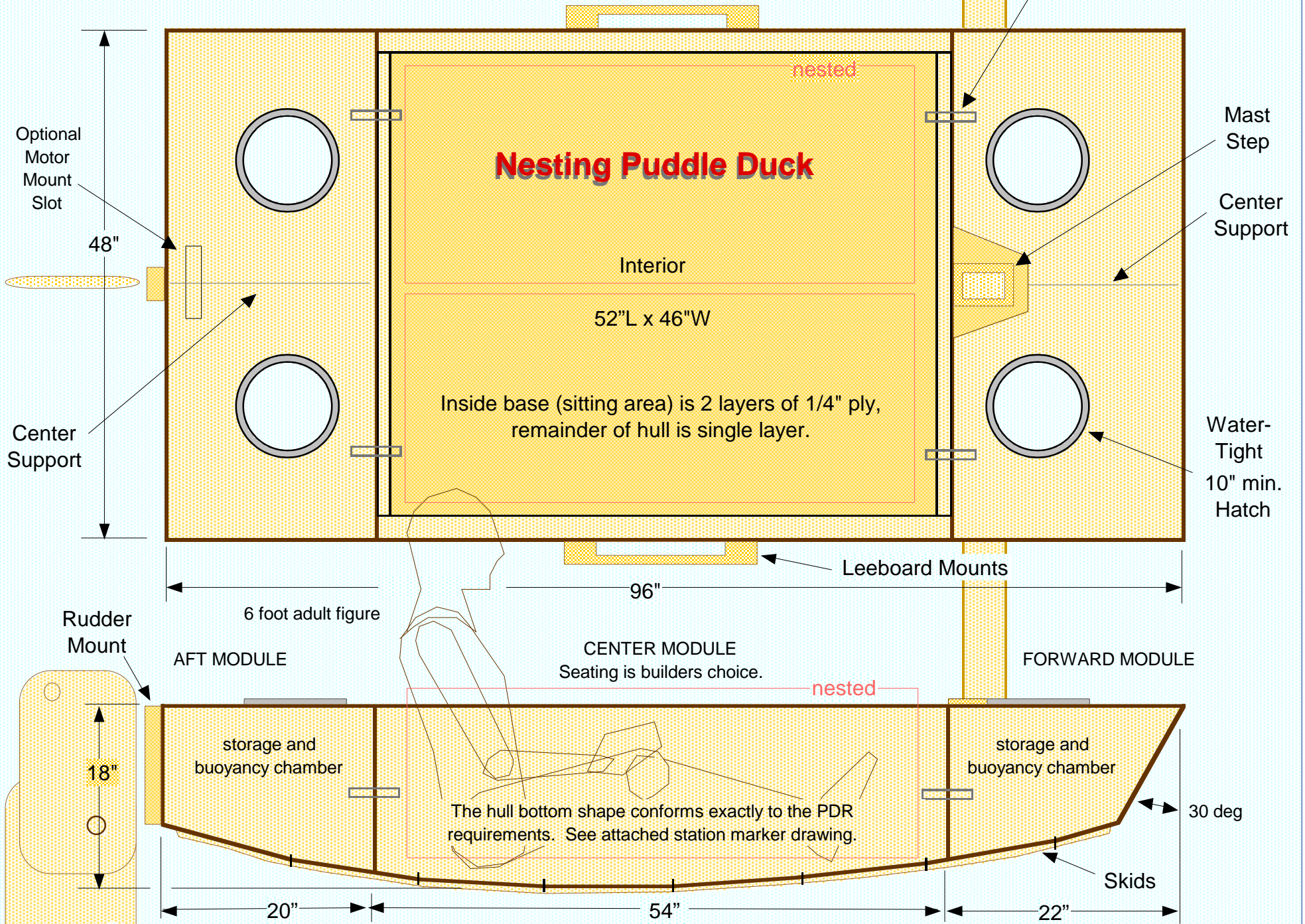

MODULAR PDRacer

PANEL DIMENSIONS

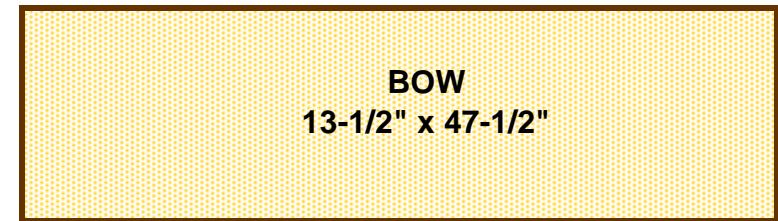
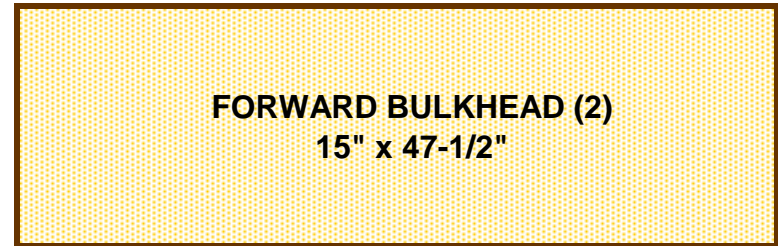
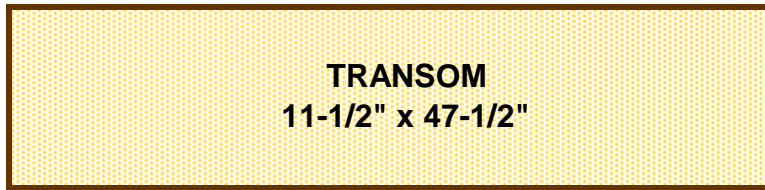
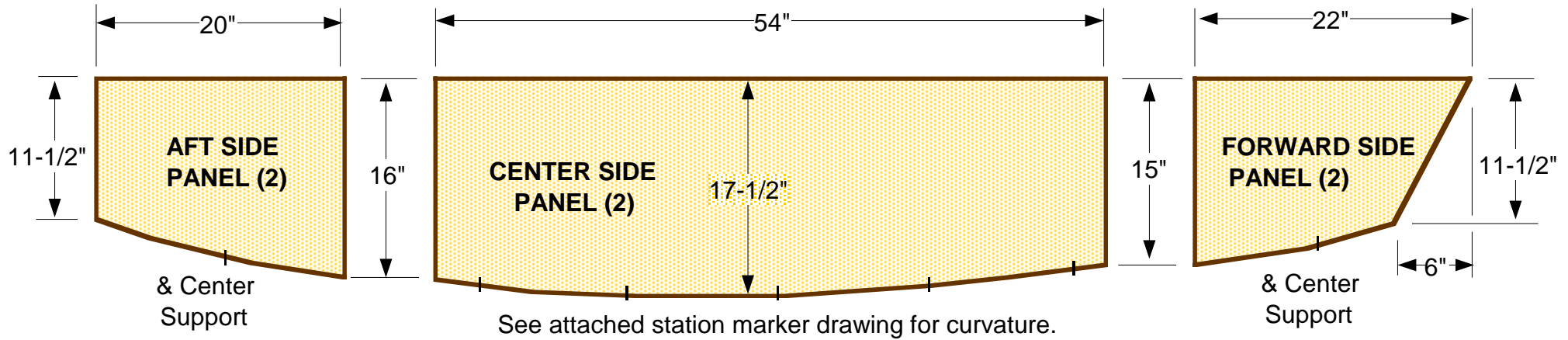

Waterproof Hatch size, type and location are builders option.

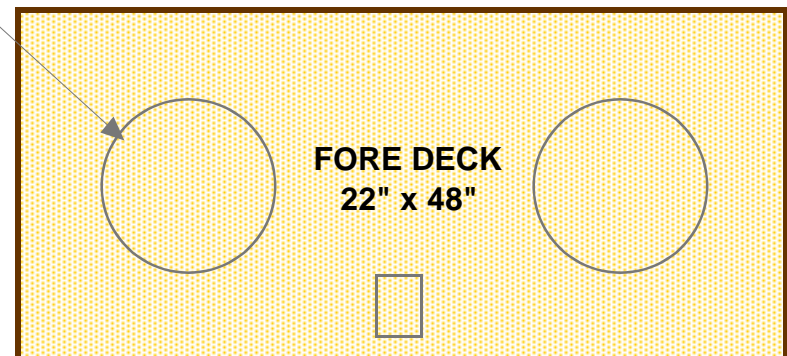
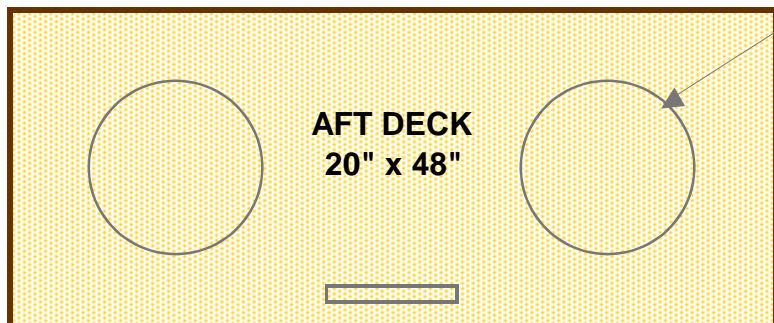

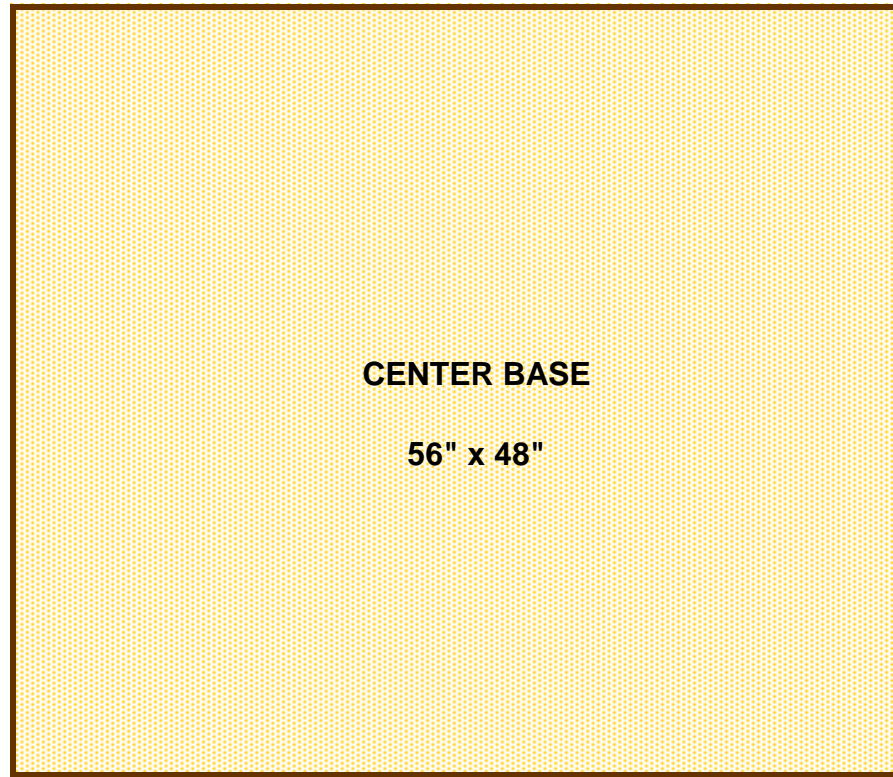
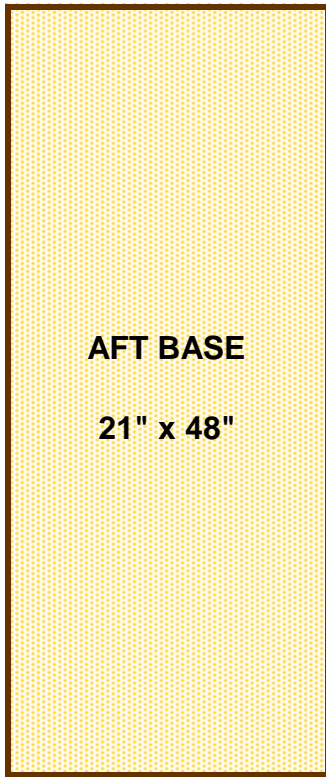

The sketch below is from the PDRacer Assembly Manual. Use it to form the shape of the hull bottom. Probably the best way is to draw this on a 9 foot roll of heavy paper, cut it out, and then trace the form onto the various plywood panels. Follow the PDR assembly plans for more detail.

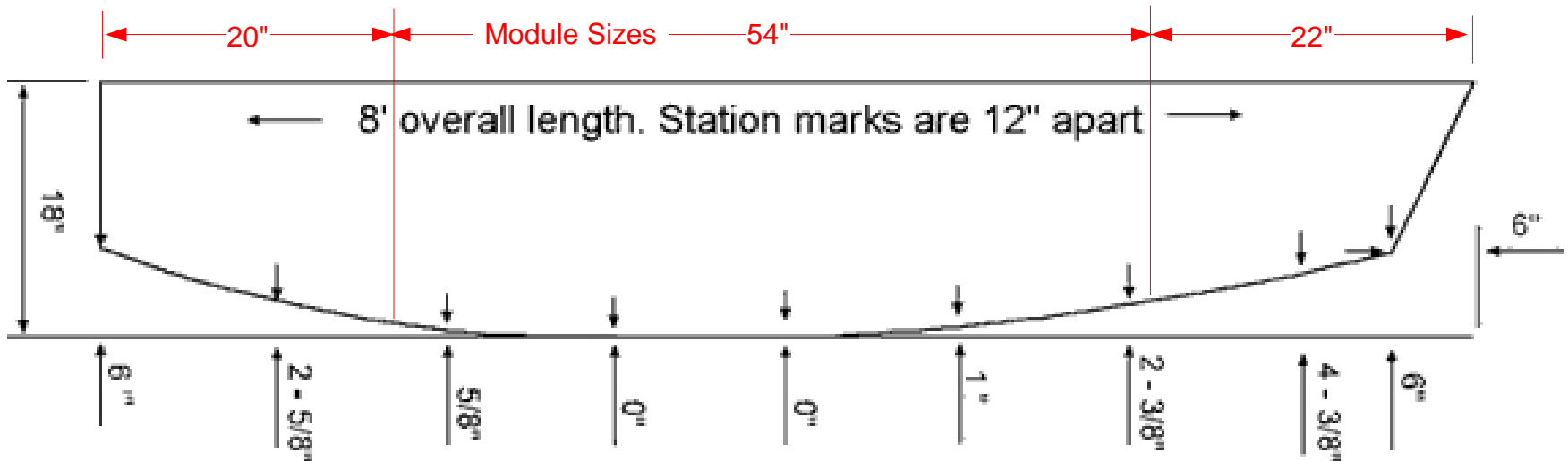

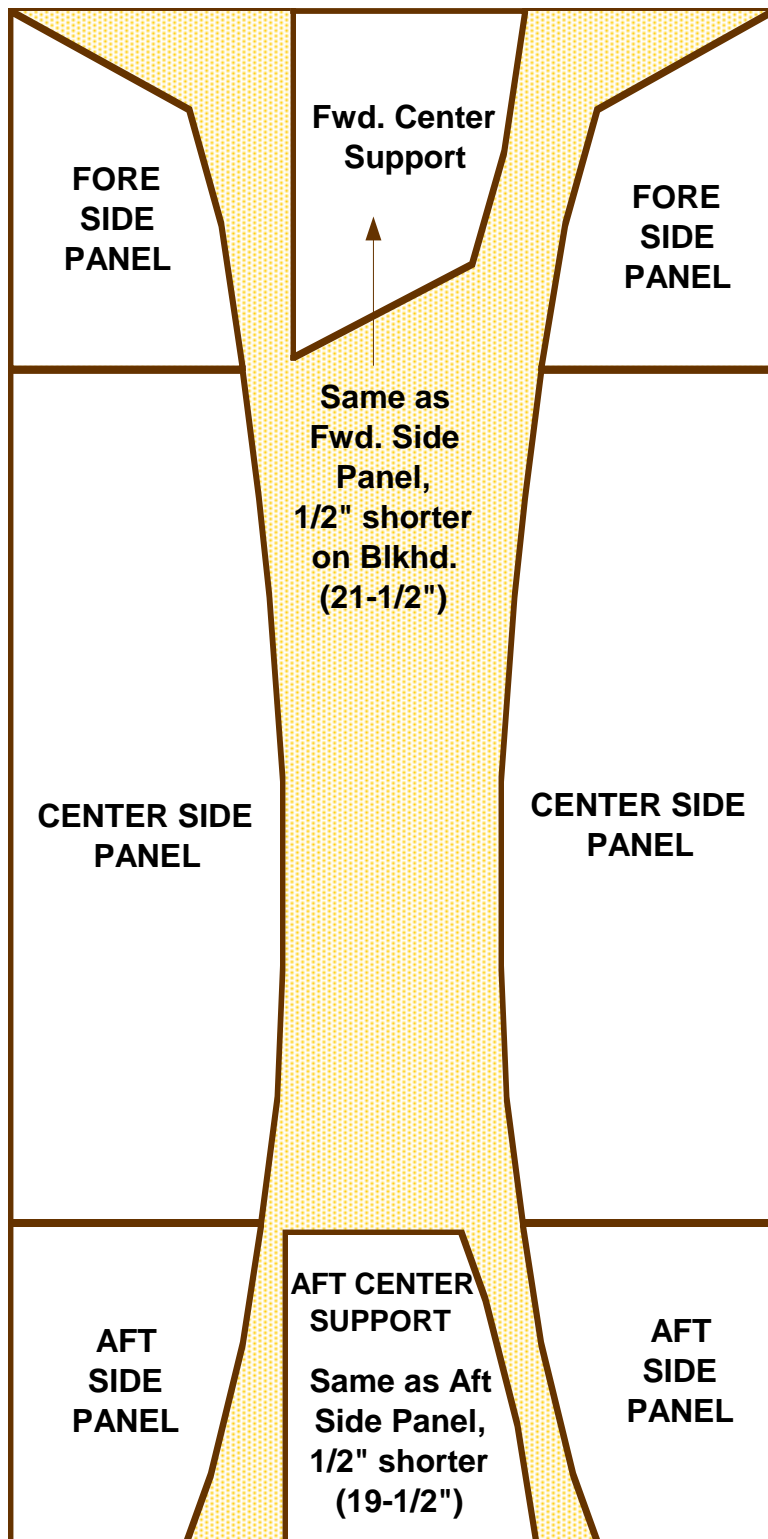

**MODULAR
PDRacer**

**PLYWOOD
LAYOUT**

**1/4" (6 mm)
Plywood
4' x 8'
sheets**

"Fit at Assembly" means that the outline of the panel is to be measured or traced from the assembly it is to be mated to. Then it is cut to shape, and becomes a perfect fit, without bothersome dimensioning.

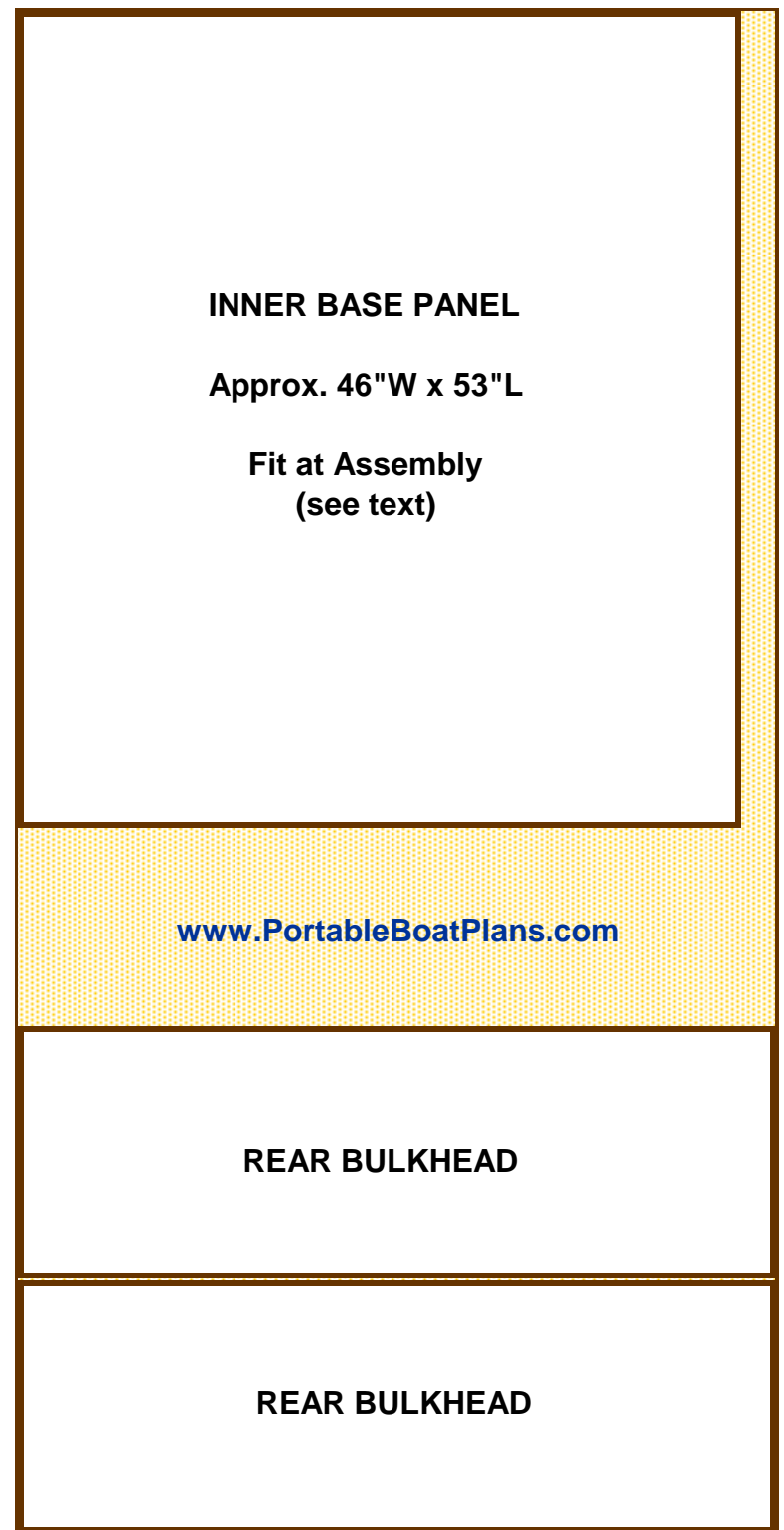

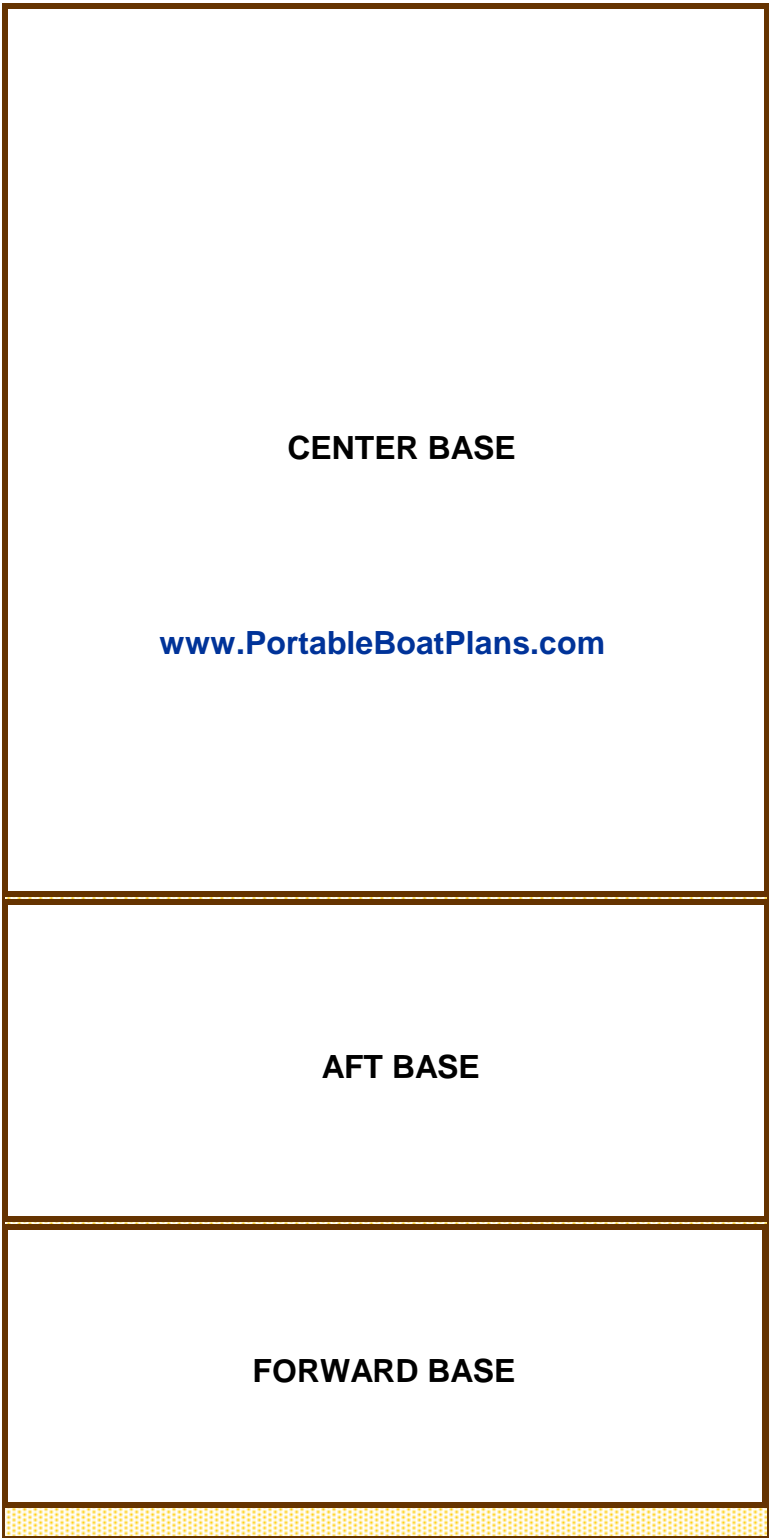

**MODULAR
PDRacer**

**PLYWOOD
LAYOUT**

**1/4" (6 mm)
Plywood
4' x 8'
sheets**

These plywood layouts provide all adjacent panels with the same grain orientation.

F.Y.I.
All sketches are hand drawn and may exhibit flaws, but the data depicted is accurate, and the dimensions are the most important.

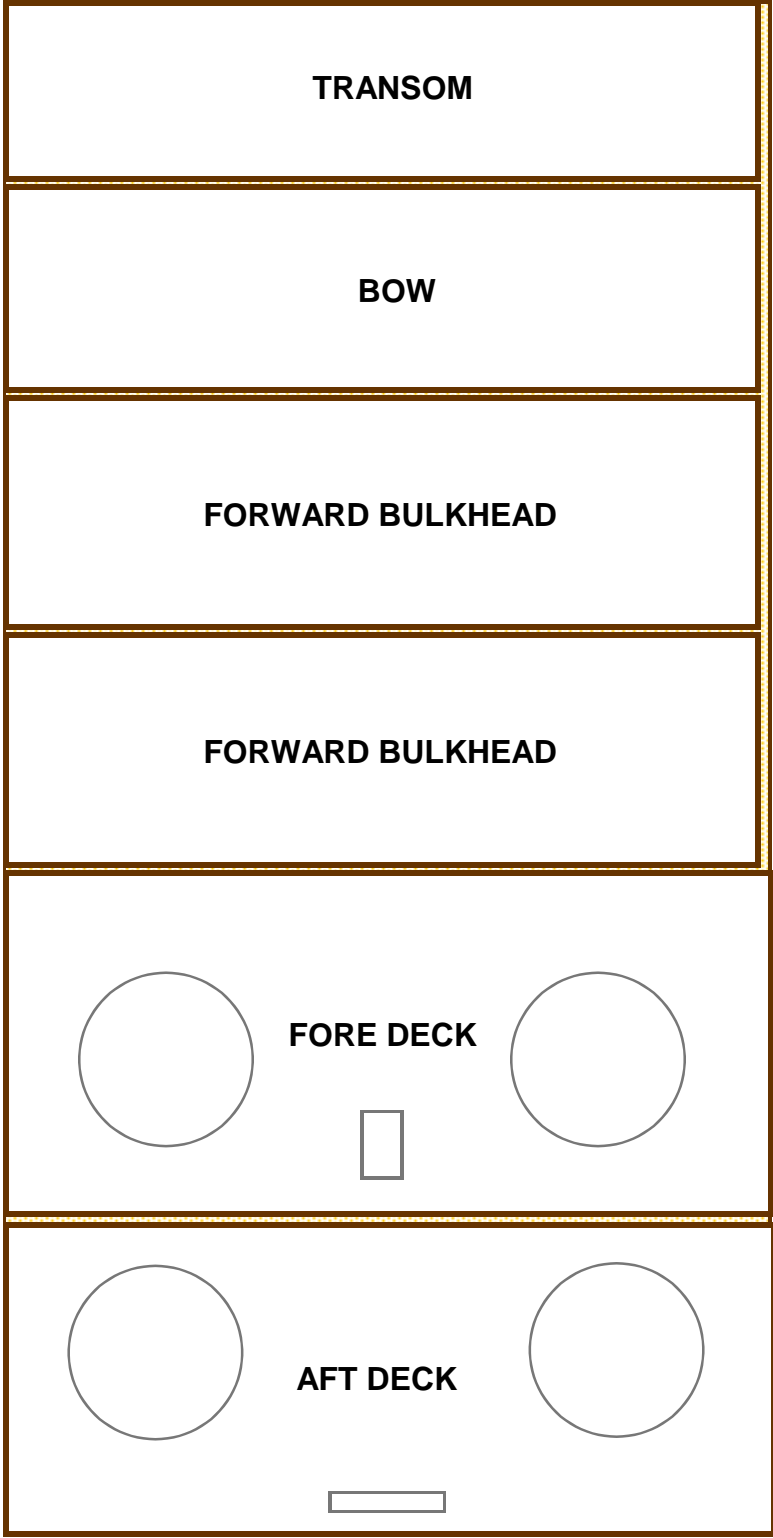

MODULAR PDRacer SIMPLE GRAPHIC ASSEMBLY INSTRUCTIONS.

Read Completely Before Starting the Project .

Start by cutting each Bulkhead and Side Panel from the plywood Sheet. It is important you cut straight lines, so use a solid straightedge to guide the jigsaw. Place the good side of plywood down while cutting, which reduces splintering on the boats outside edges. Lightly sand all edges after cutting. Insure that the Bulkhead pairs are identical, as these form the final hull shape.

The following process will be the same for all panel assemblies..

CENTER Module

Apply 1 x 2 lumber as shown on all edges of the Bulkheads.

Using **TiteBond 3 Glue** and **#6 x 3/4" Stainless Screws**, glue and screw the supports in place., as shown in the following sketches. Lay bulkheads on a flat surface to cure to prevent warpage.

Allow assembly to cure for at least 4 hours, prior to the next step.

Some photos and sketches may be of a similar boat that uses the same panel construction methods.



REMEMBER : MEASURE TWICE, CUT ONCE !

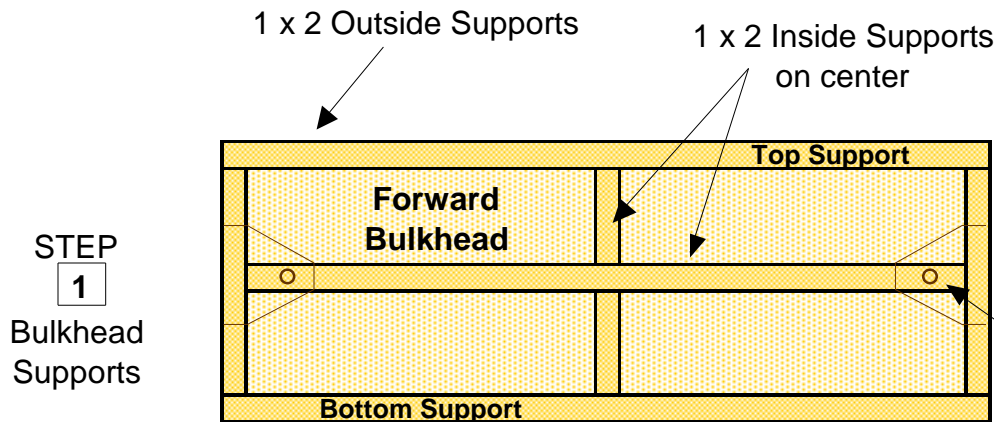

Panel good side out

Glue and screw supports to inside surface of Bulkheads. All screw holes must have countersinks on the outside.

**REPEAT THIS PROCESS FOR THE CENTER MODULE REAR BULKHEAD.
(Can be done at the same time.)**

Keeping the Bulkhead flat is critical for proper hull alignment.

www.PortableBoatPlans.com

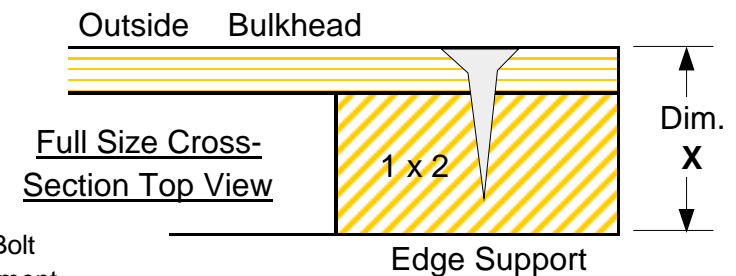

Safety Bolt Reinforcement to be added later.

Remember, 1 x 2 lumber is actually 3/4" x 1-1/2" size.

See Alternate assembly sketch of Bottom Support on next page.

Always wear latex gloves when gluing or painting.

MODULAR PDRacer

Murphy's Law of Boat Building: " The Glue Dries Before The Mistake Is Found ! "

STEP

2

Side
Supports

Using the exact same process as above, glue and screw the 1 x 1 supports to the Side Panels, as shown at right. Good side out.

Select an easy to bend stringer for the chine support, as it will have to be bent into position, as shown in the photo below. 1 inch nails can be used to hold it in position from the inside, until the screws are applied from the outside. Apply screws about every 6 to 8 inches. Remove the nails.

Drawings may not be to scale.

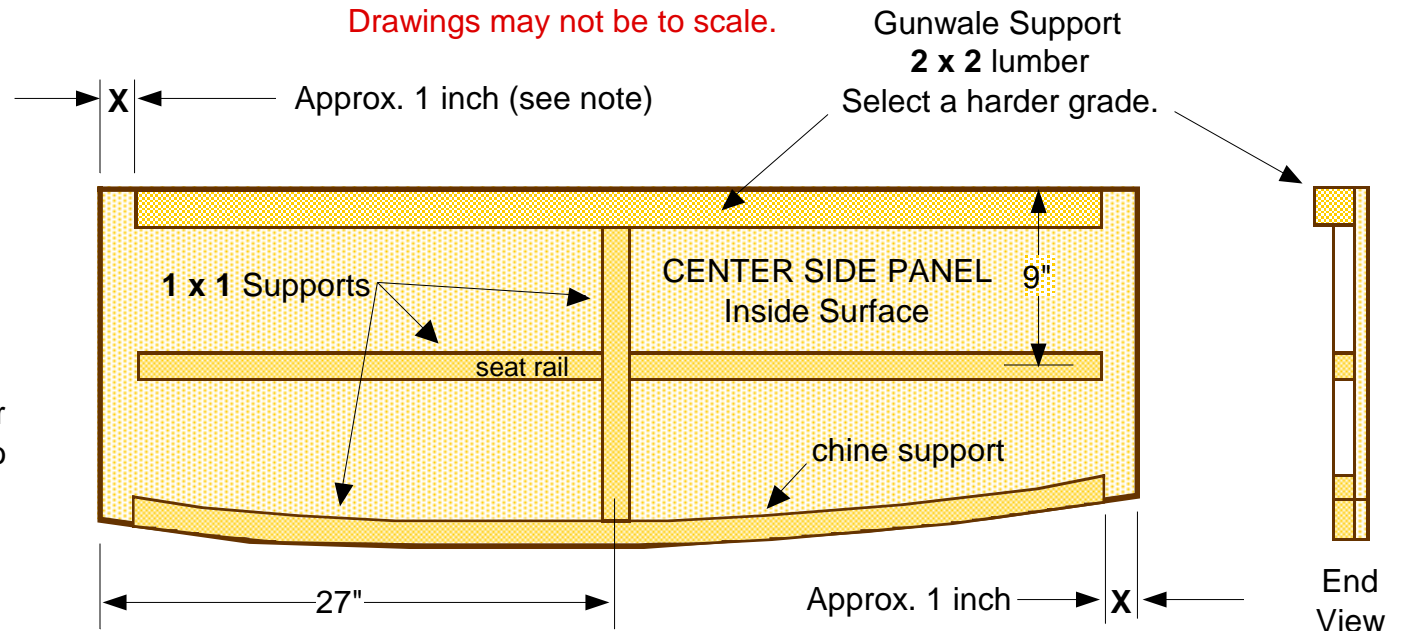

The 1 x 1 Supports can be a 1 x 2 cut in half.

Remember, the two side panels are mirror images of each other.



Measure the exact thickness of the Bulkhead assembly, Dimension X, in sketch on page 8. This is the dimension you must allow at the ends of the supports on the Side Panels. You can pre-cut these, or cut them after they are assembled. This will provide a perfect fit of Side Panels to Bulkhead.

Alternate method of constructing lower bulkhead supports. Provides full support of base panel. Use Angle Template on **Page 24**.

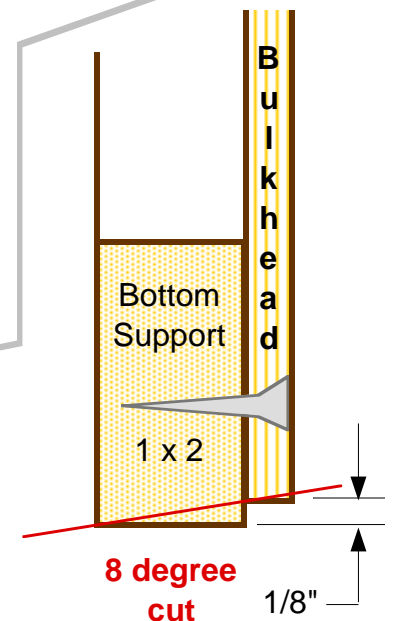

MODULAR PDRacer

STEP

3

Bulkheads

Apply TB3 (TiteBond III) glue to the edges of the Center Forward Bulkhead, smooth out with finger. Allow to dry for a couple of minutes. Do the same for the end side surface of the Center Side Panel to be glued. This allows the glue to penetrate the wood and form a bonding joint. Next, apply a thick bead of TB3 glue to the edge of the Bulkhead, press a side panel in place, and hold with High Stick Masking Tape. Panel goes on the outside of the bulkhead, and the 'good side' should be out. Insure a square corner. Small #6 x 3/4" SS Screws should be used to hold the panel in position, about 3 per side. Do the same for the opposite side panel. Remove tape after applying screws.

Then repeat the process for the Center Rear Bulkhead. Insure that the panels are square to the bulkheads.

Allow to cure for at least **4** hours at room temperature.

Next step is to prepare for the Base assembly.

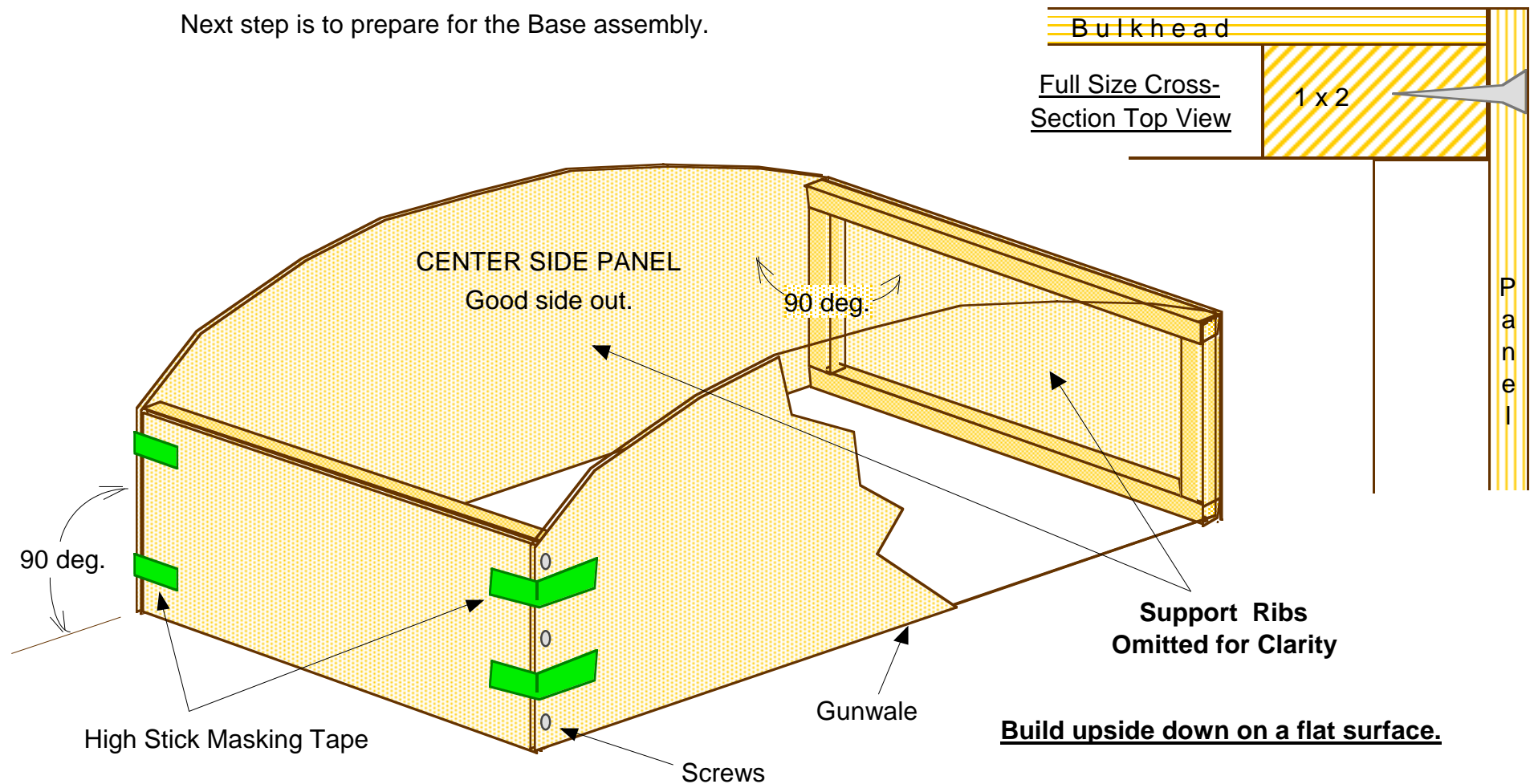

MODULAR PDRacer

STEP 4
Base Before placing the base on the assembly, first check that the hull is a true rectangle. Measure from corner **A** to corner **B**. Then measure from corner **C** to **D**. Both dimensions should be the same. If not, lightly squeeze the assembly into alignment. Hold in that position with a measured length of 1 x 2 from one shorter inside corner to the opposite inside corner.

Next, apply glue, as you did on the bulkheads, to the interface of the assembly and base panel (good side out). Smooth with finger, and apply a second bead all around. Pre-drill and counter-sink the screw holes in the base. Place the base on the assembly and line up the sides and ends. Start applying screws at the center, and continue the length of the section, by alternating from one side to the other. Finally, screw down the ends to the bulkheads, but do not overtighten as it may warp the base panel. Allow the assembly to cure for at least 4 hours.



Photo from PDR website

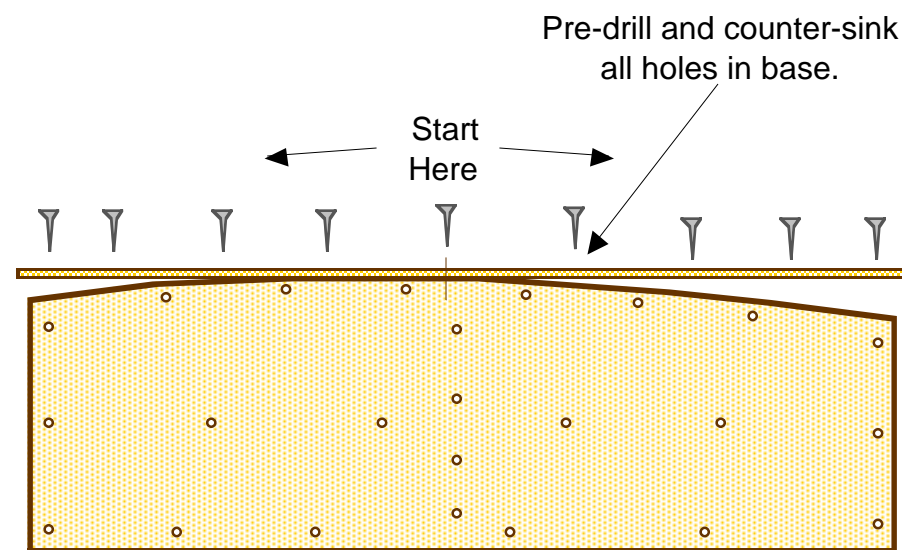
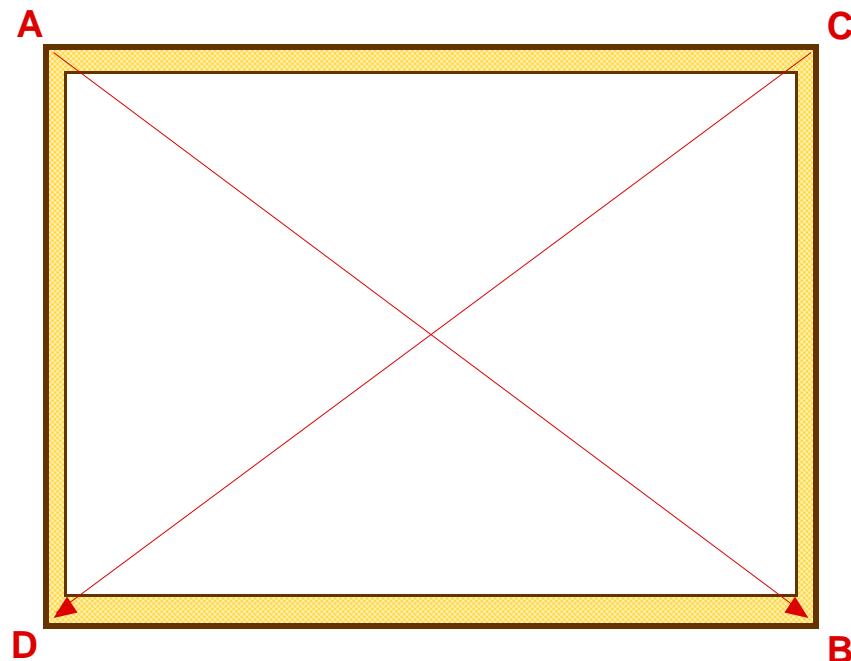

Assemble upside down.

Some overhang may exist on the ends. After the glue has cured, trim flush to the bulkheads. Also trim, with a wood file, the base to sides. Sand lightly all surfaces.

STEP

5

Skids

Three 1 x 2 skids will be placed on the bottom of the hull for protection and rigidity. They will be equally spaced from the center, as shown in the following sketch. The skids will have to bend over the base, so choose the wood carefully.

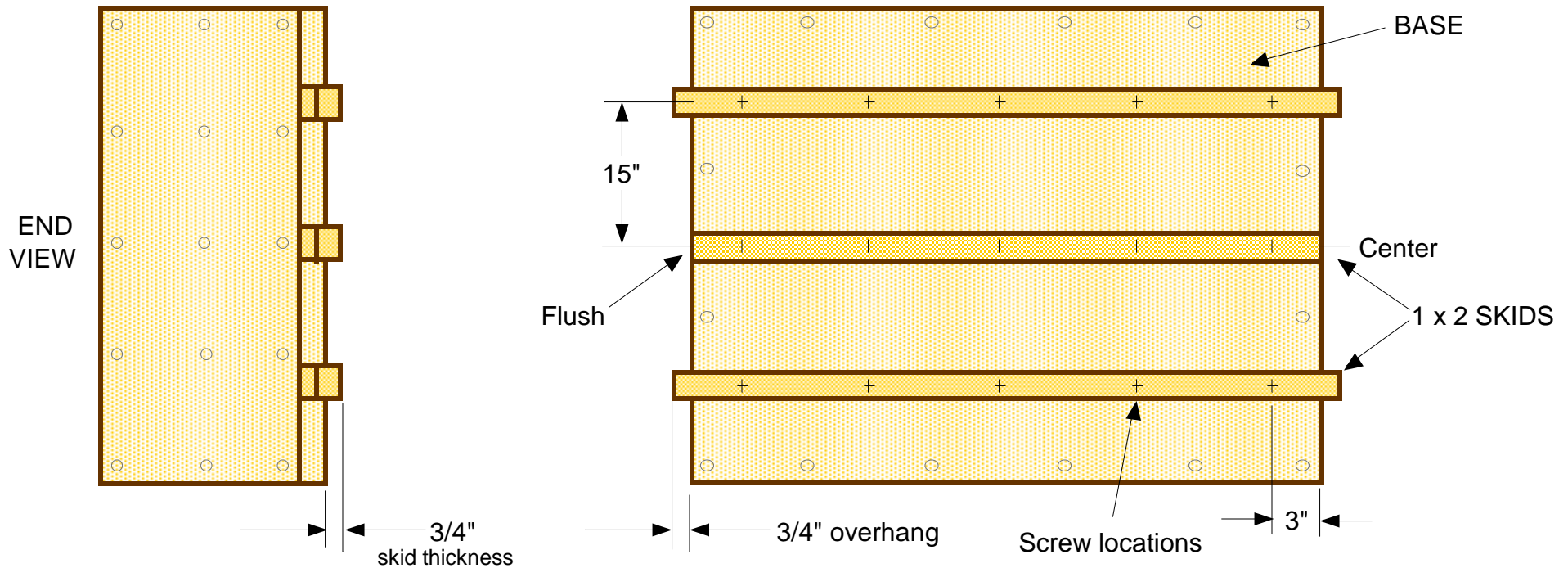

The two outside skids overhang the end of the center module to give support to the forward and rear modules during boat assembly. The following is an easy method of locating and attaching the skids to the hull.

First, cut the skids to length. Mark, with a pencil, the center of the base at both module ends. Then mark the 15 inch center of the outside skids. Draw these center lines the length of the module.

Next, mark the location of screw holes to be drilled, 5 holes per skid equally spaced as shown above. Use #6 x 3/4" long Stainless screws. Drill the screw clearance holes through the base from the outside. Turn the assembly over and countersink all the holes for the screw heads on the inside. This is where the screws will be applied.

Glue and screw each skid in place. This is best done by 2 people, one glues and holds the skid in place while the other applies the screws. When complete allow at least 4 hours for the glue to cure.

NOTE: All additions to support the Mast, Seating, Storage or any other modification to the hull modules, must be completed with the modules, but prior to the application of any water protection or finish.

MODULAR PDRacer

STEP

6

Inside Floor

For some people, the single 1/4" floor will be sufficient, but for most a second floor will be required. If you weigh over 175 pounds, it is an essential element.

ASSEMBLY METHOD

Measure the length and width of the inside base opening. This would be inside the base support strips, approx. 46 inches by 53 inches. The length dimension must be along the radius of the base surface.

Cut the panel to this size, and test fit it into the inside base opening. Trim as necessary to get a good fit. You will have to press down on the center of the panel during this process. Partially remove the panel, and look where the screws for the skids are. Mark the location of the 3 rows on the top surface of the new panel. Remove the panel. Also note the location of the screws along the skid line. Now, drill and counter-sink 3 rows of screw holes so that they do not interfere with the skid screws.

Next, apply thick beads of TB3 glue in rows over the entire base panel, as shown in sketch at right. Using #6 x 1" Stainless Screws, start in the center and screw the inner base panel through the outer base and into the skids. This will provide a solid structure from which you can safely operate the PDRacer. This second base panel step can be performed prior to adding the skids. Your option.

The next step is to place Deck Strips on the gunwale area of the assembly, as defined on the next page.

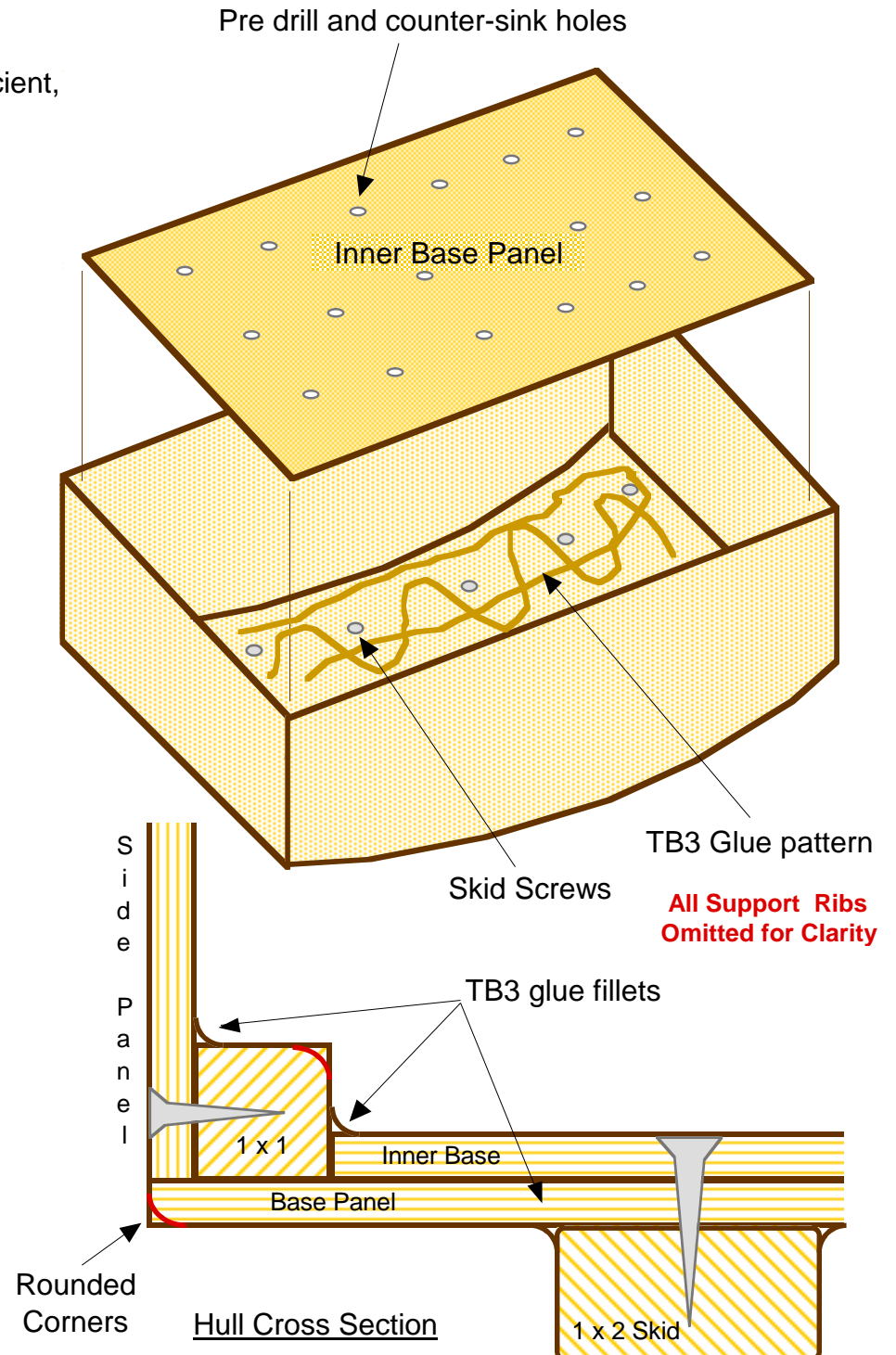

STEP

7 Addition of DECK STRIPS

Cut Deck Strips from leftover 1/4" plywood, and fit as shown in sketches. Make them flush with the inside supports and the outside panels.

Glue and screw in position. These will provide a flush surface to the end modules, and give the center module a finished look. If possible, make the grain run in the same direction as the end module decks.

DECK STRIPS

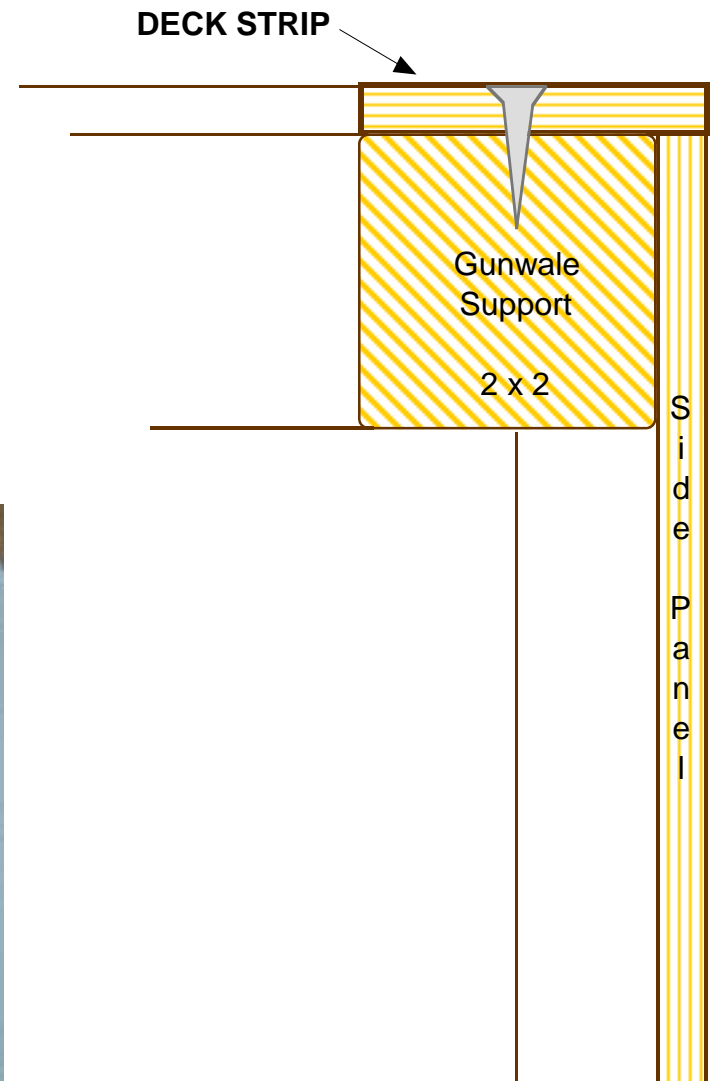
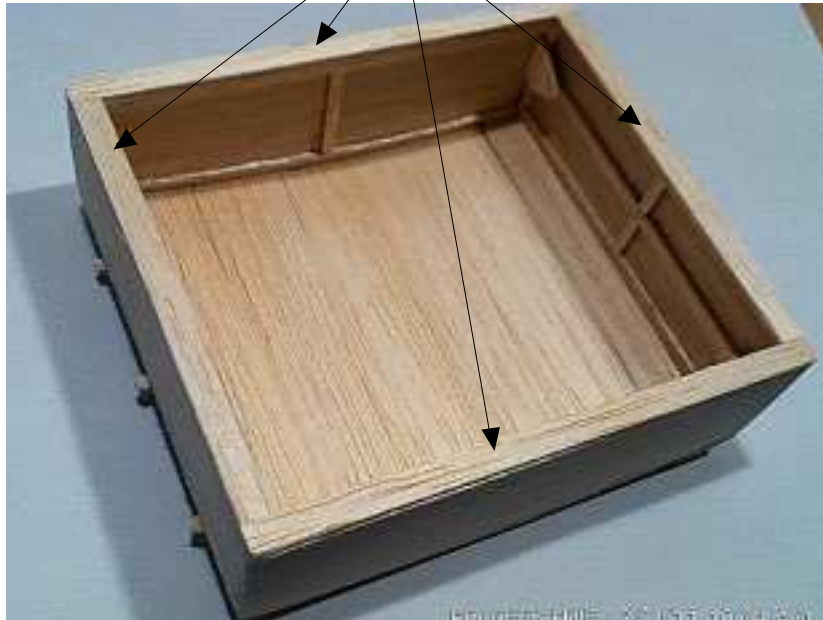

Finally, fill all joint openings with TB3 glue, smooth with finger, and allow to cure for at least 4 hours.

Repeat the "fill with glue" process for all hull joints that may exhibit voids or have insufficient glue. Allow to cure. Sand smooth all exterior and interior surfaces, round sharp edges, in preparation of applying a finish.

Lay this module aside, take a break, and look ahead to the start of work on the forward module.

MODULAR PDRacer

STEP

8 FORWARD Module Bulkhead & Bow Panels

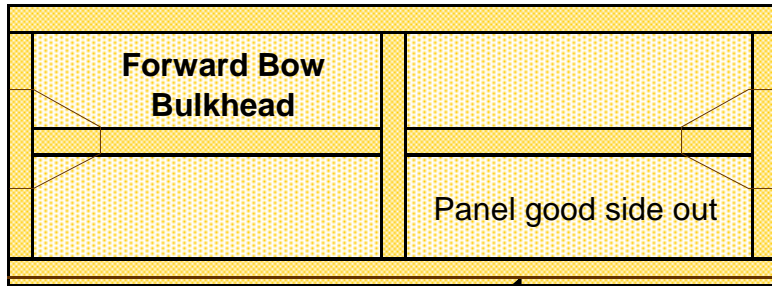

Bottom Support

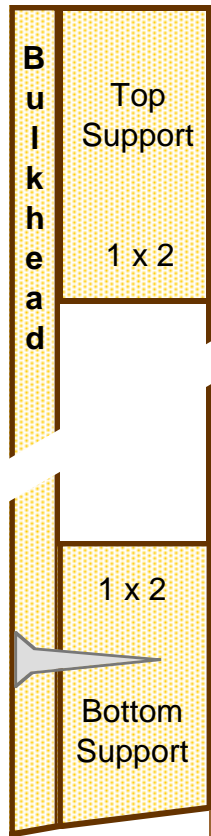

Forward Bulkhead

1 x 2's

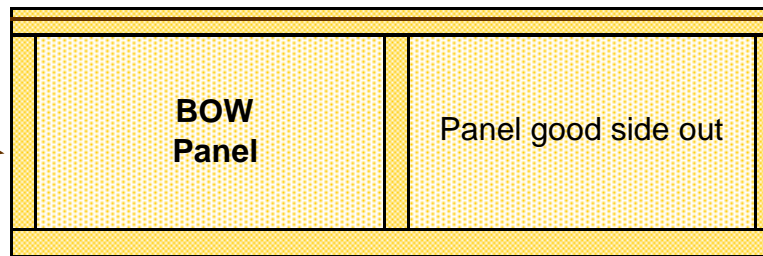

Add 1 x 2 supports just as you did for the Center Module Bulkheads. Note the angle cuts to the Bottom and Top Supports. It is also wise to place the Forward Module Bulkhead against the Center Module Bulkhead to check for proper alignment and fit.

This method of constructing upper and lower bulkhead supports provides full support of the base panel.

TEMPLATES for measuring the angles are on Page 24

At the completion of all 3 modules, hull reinforcements will be added to each, for the four Safety Bolts that will hold them all together.

NOTE: The Top & Bottom Support of the Bow Panel must be located offset to the bulkhead. See sketch at right.

These are probably the most difficult cuts of the whole assembly. If the angles are too difficult, you can just offset the supports so that the base contacts the edge of each.

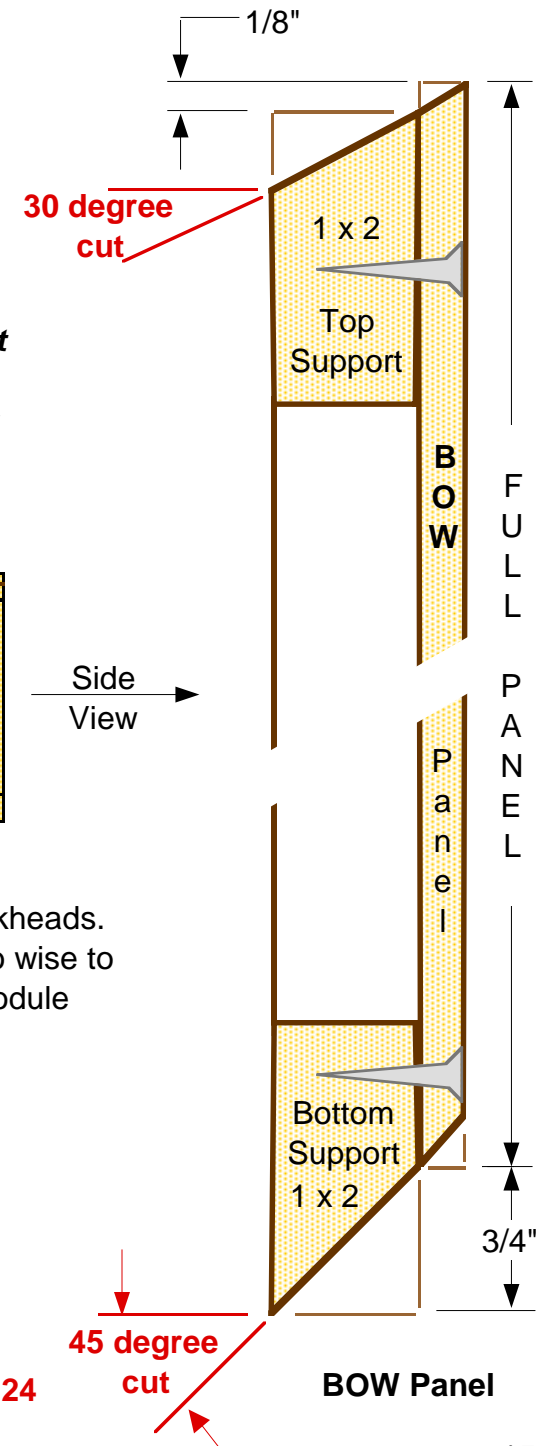

Side View

BOW Panel

MODULAR PDRacer

STEP

9 FORWARD Module Side Panels

Use the same process as the Center Module Side Panels, Step 2. All supports are 1 x 1 lumber, glued and screwed to the panels. Allow clearance for the Bulkheads at each end of the Supports, and apply a center rib as shown, for side rigidity .

STEP

10 FORWARD Module Assembly

Using the same process as for the Center Module, Step 3, glue and screw the Forward Side Panel assemblies to the Bulkhead. Insure the Panels are aligned with each other. Next, glue and screw the Bow Panel to the Side Panels. It might be easier if this was all done upside down. Again, measure from A-B & C-D to insure a square assembly.

At this point it must be determined how the mast will be stepped, and what changes to the structure are required.

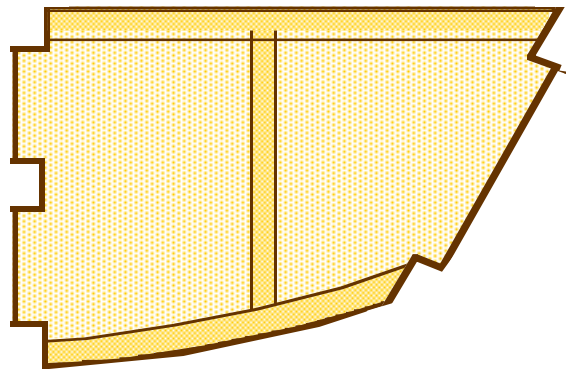

Locate the Bow Center Panel so that it clears the Mast, or any other supporting structure.

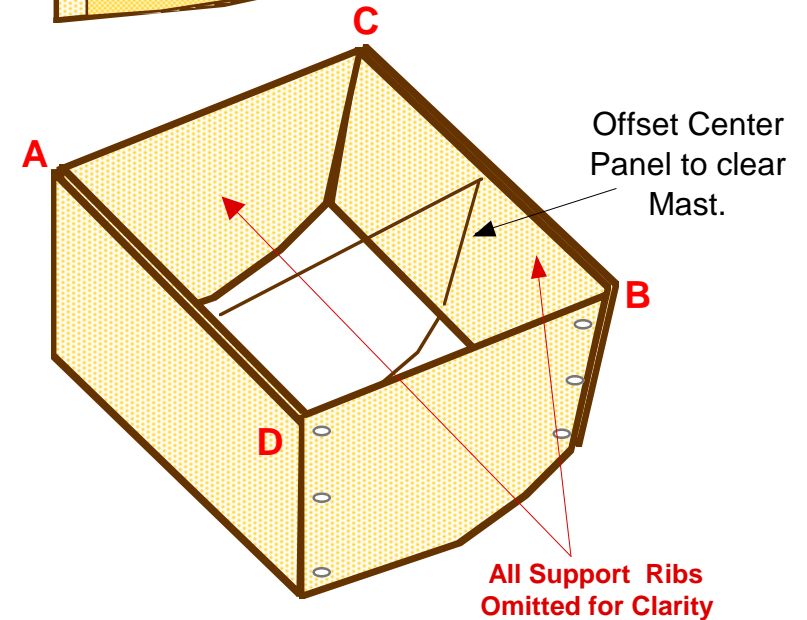
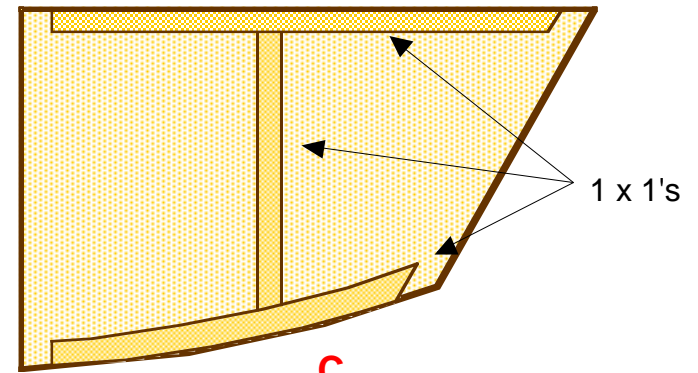

STEP

11 Bow Center Panel

The purpose of the Center Panel is to give structural support to the Deck, Mast and the Base of the Forward Module. Without it, thicker plywood would be required.

Apply the Supports just as you did for the Side Panels. Cut the notches as shown in the sketch at left. Pre-fit the Panel to the assembly to insure all surfaces line up properly. Again, this can best be done upside down on a flat surface. The Center Panel should be glued and screwed to a vertical support on the Bulkhead and to the Bow Panel support.

This location may vary depending on Mast placement and support. Allow glue to cure prior to next step.

MODULAR PDRacer

STEP

12 Forward Module Deck Assembly

Before you fit the Fore Deck to the assembly, you must decide what type of hatch openings you want. Also plan for the mast opening. Cut and fit them at this time.

Next check the A-B & C-D dimensions, and correct as necessary. Now, apply TB3 as you did on the previous assemblies. It would be wise to also pre-drill and counter-sink the holes for the screws. Mark the center location of the center panel Support, as it will be on the hull center. Glue and screw the Fore Deck in place. Turn the assembly over and prepare for the base attachment.

STEP

13 Safety Bolt Reinforcement Pads

Because this will be an enclosed assembly, it will be necessary to add the Reinforcement Pads at this time.

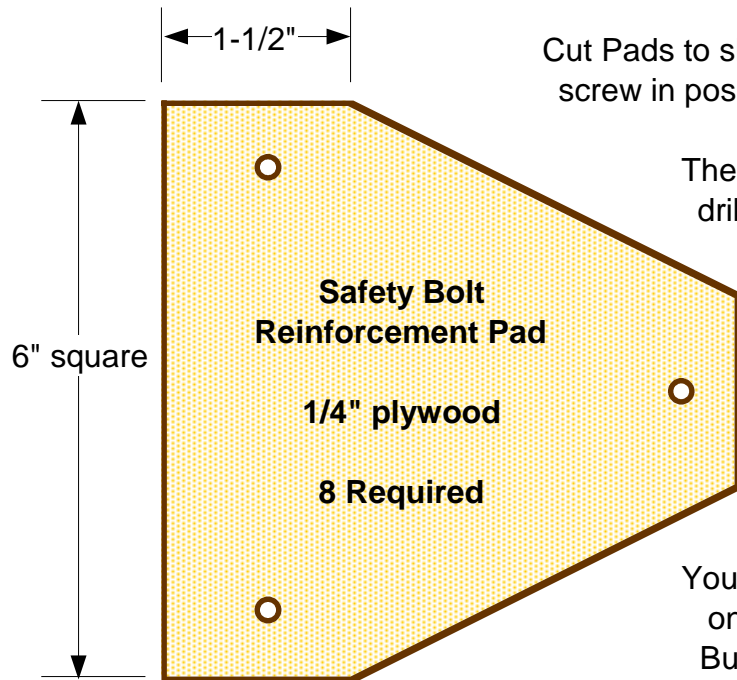

Cut Pads to shape per the sketch at left, glue and screw in position as shown in the sketch below.

The Security Bolt holes will be drilled when all the modules are complete.

You can also place these on the Center Module Bulkheads at this time.

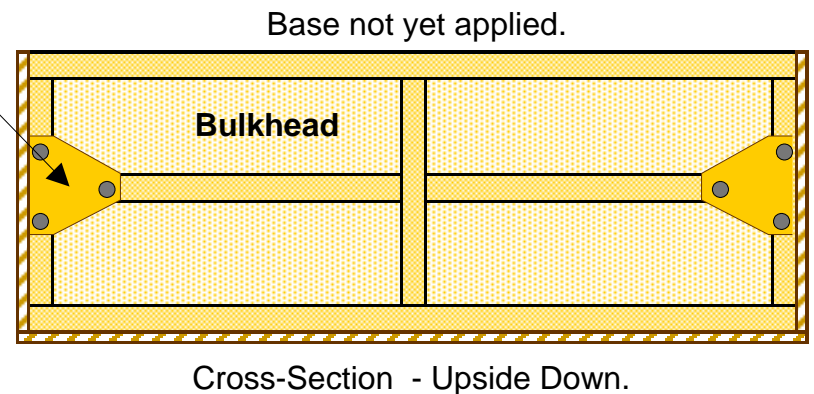
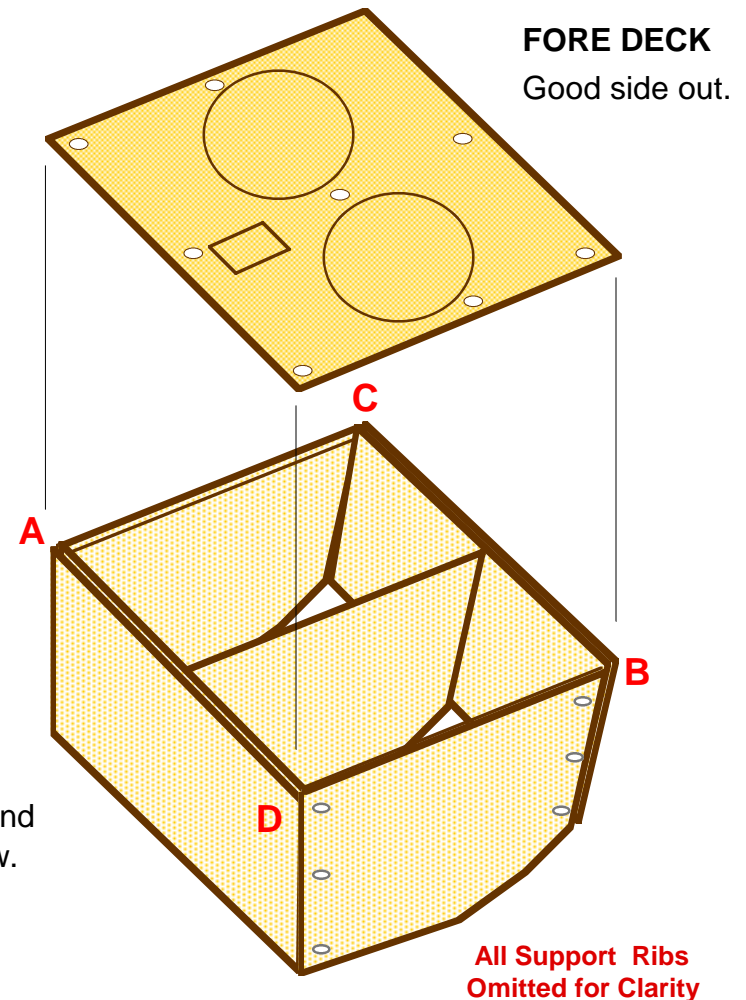

MODULAR PDRacer

STEP

14 Forward Module Base Assembly

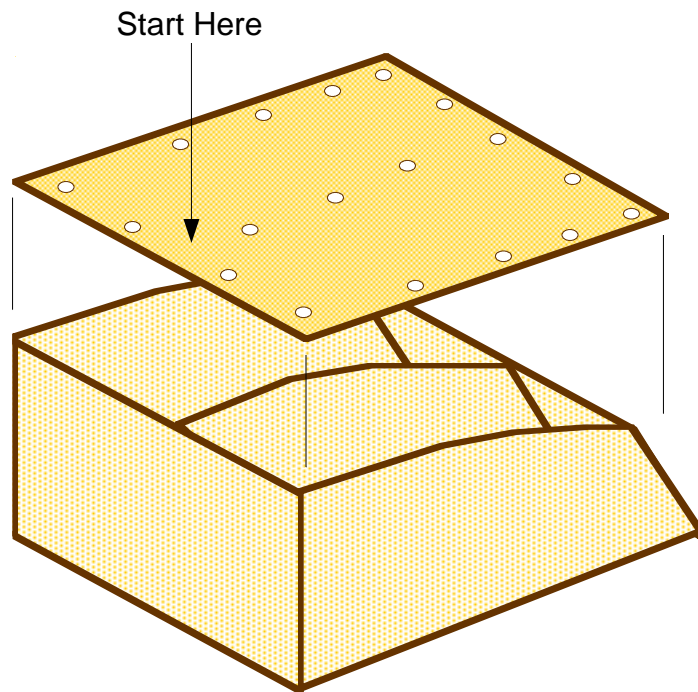

Like the Deck Panel, pre-drill the screw holes, and measure and fit the Base Panel. Allow a little extra length, which can be trimmed later. Start the glue and screw process at the bulkhead, and work forward, alternating from side to side until the Bow is met. Check to insure flatness, and finish assembly of the Base. Allow the glue to cure for at least 4 hours. Trim any excess that may be present, and lightly sand all module surfaces in preparation for finishing.

STEP

15 Moisture Protection

Now is a good time to mention that all three hull modules will have to be waterproof treated prior to the actual finish application. This can take many forms, but I recommend using **Thompsons Water Seal**. It is a clear liquid that penetrates the wood and prevents the absorption of moisture. Apply, with a brush, to all surfaces inside and outside. When first applied, it also prevents paint from sticking to the wood! So, it is important that you apply the Thompsons and allow it to dry for at least 48 hours. Follow the Manufacturer's Instructions. Apply the Skids (next page) **before** the application of Thompsons. Lightly sand all surfaces prior to painting.

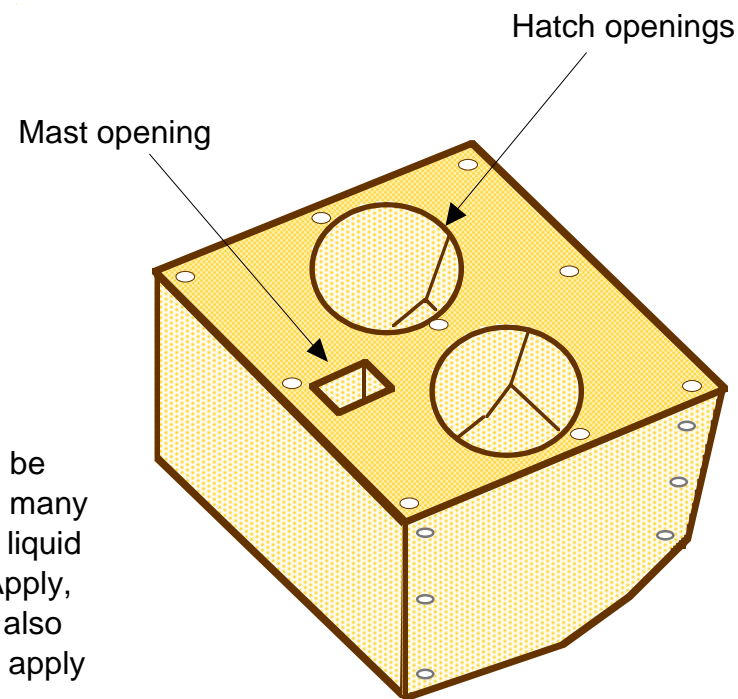

Nearly Completed Module

Drawings may not be to scale.

MODULAR PDRacer

STEP

16 Forward Module Skids

Use the same Skid assembly process as on the Center Module. Align the skids as shown, in line with the outer skids on the Center Module. Glue, and then screw from the inside. The 1" recess is to clear the protruding mating skids.

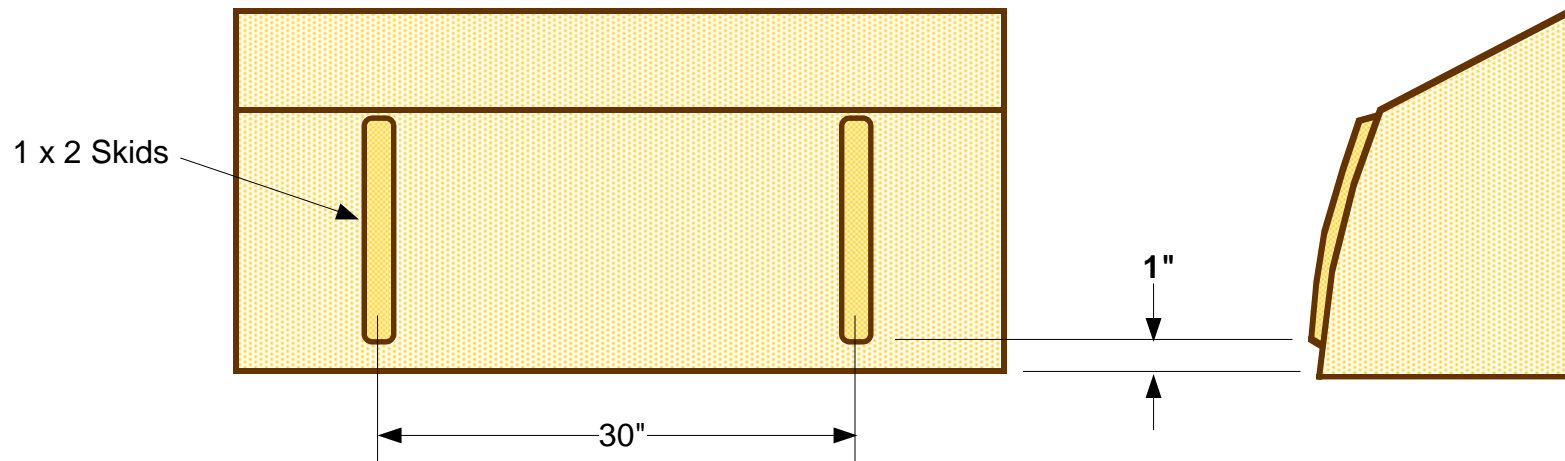

End of Forward Module

STEP

17 REAR Module Bulkhead

The Rear Module Bulkhead is assembled exactly the same way as the Center Module Rear Bulkhead, except the 8 degree cut on the bottom is opposite that of the Center Module. Place the Rear Bulkhead against the Center Module Rear Bulkhead to determine the fit. Trim as necessary to obtain a smooth transition.

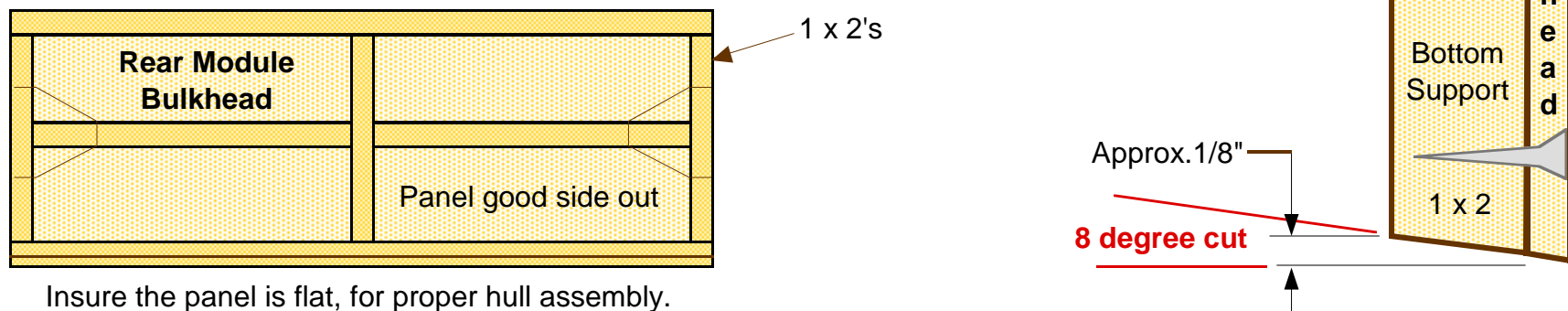

Insure the panel is flat, for proper hull assembly.

STEP

18 REAR Module Transom and Assembly

By now you know the assembly process, and this is no different. However, great thought must be given to the attachment of the Rudder assembly. Additional internal support may be needed. Also, if you intend to utilize a Trolling Motor, consider also how it will be mounted. My method is at the end of this manual. Align the Rear Module Bulkhead to the Center Module for proper fit. Otherwise all assembly techniques are the same as the Forward Module, including the Safety Bolt Reinforcements and the Water Sealing.

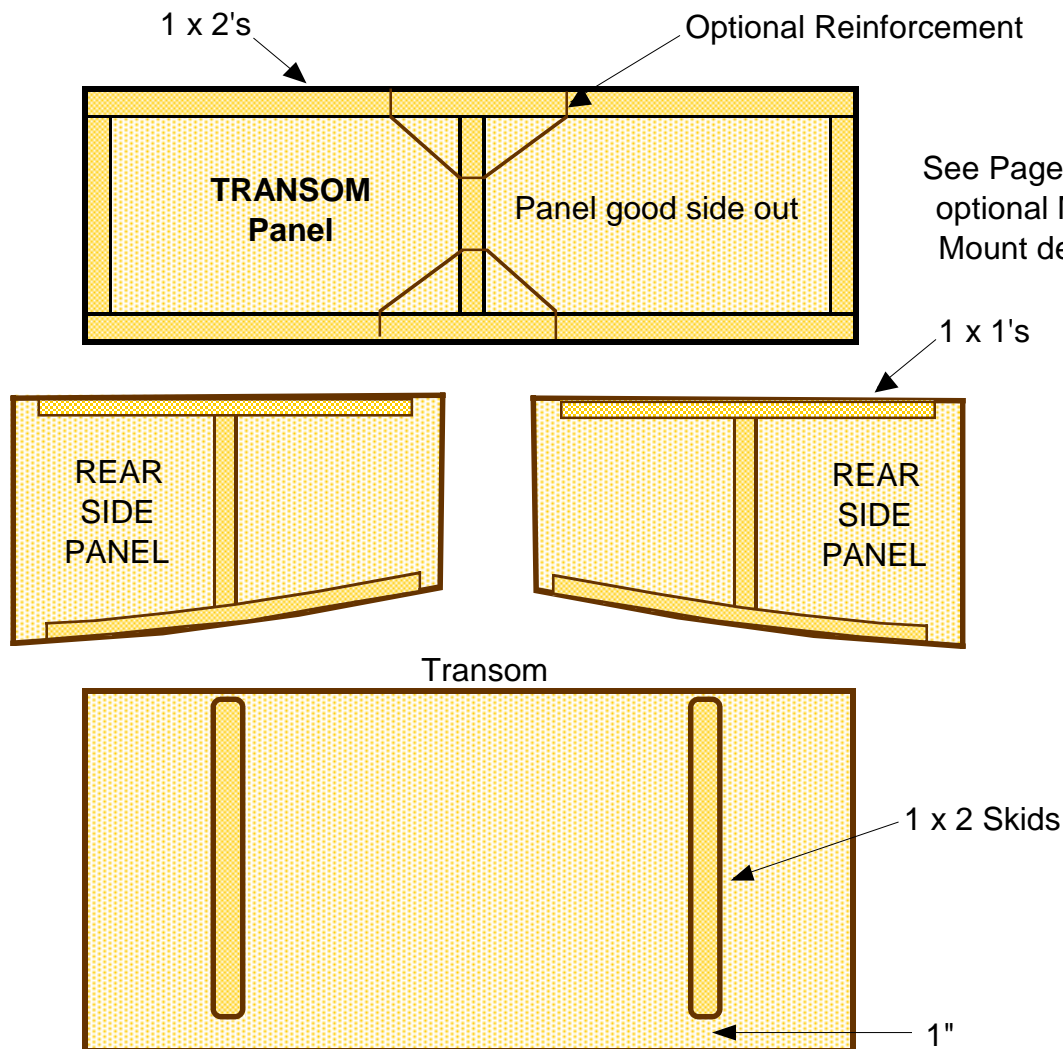

See Page 25 for optional Motor Mount details.

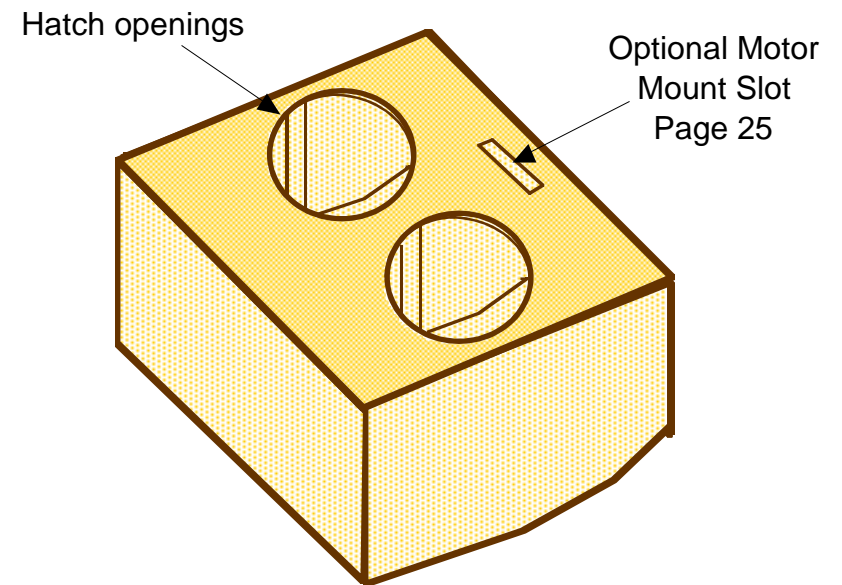
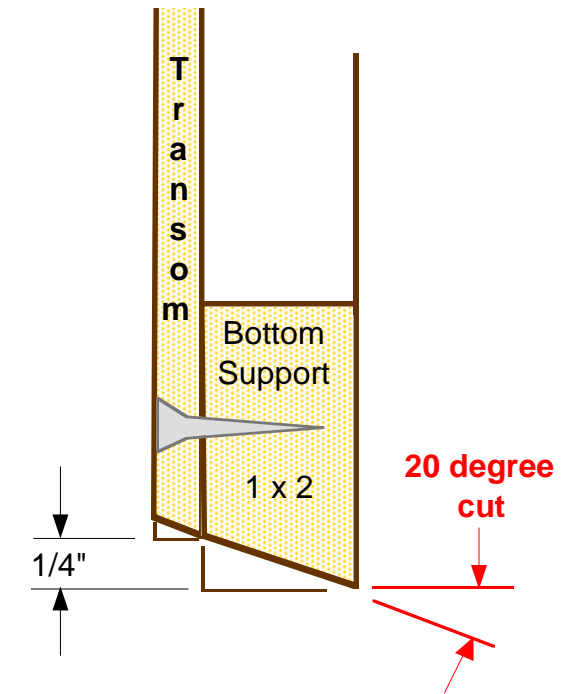

Completed Rear Module Assembly

Drawings may not be to scale.

STEP

19 PRE-FINISHING the HULL MODULES

Now that all three modules are complete, it is time to start the process of final finishing. It is important that all surfaces be sanded smooth, and the edges and corners rounded slightly, about 1/8" to 1/4" radius. I always suggest that the outside joints be sealed using the Tape & Glue process, if only to protect them from water intrusion. That's your choice.

Whatever sail rigging you have settled on, it is important that any wood supports and blocks have already been pre-fitted.

Now it is time to join the Hull Modules together, and drill the Safety Bolt Holes.

Refer to the Photos on the following page for the drilling process.

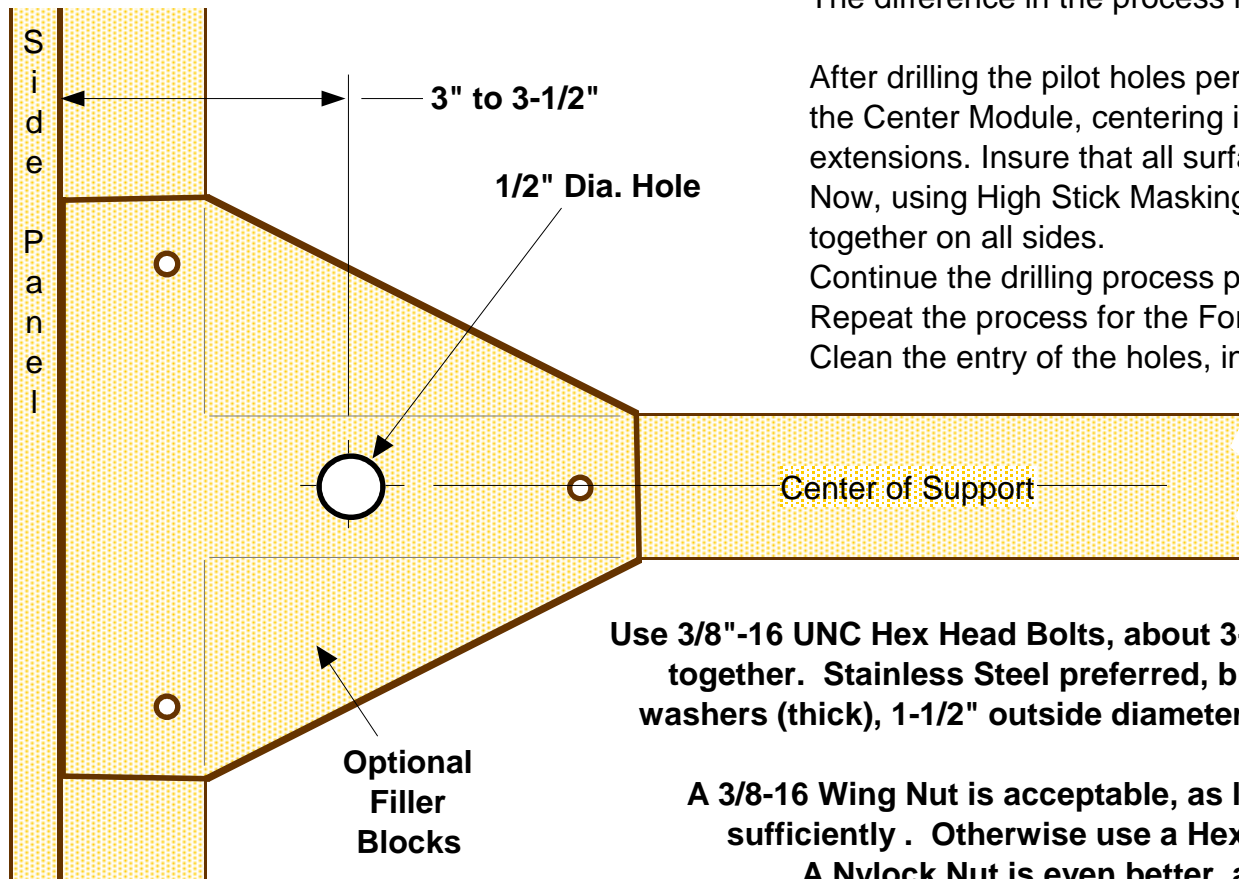

The difference in the process is as follows:

After drilling the pilot holes per Photos #1&2, align the Rear Module to the Center Module, centering it right to left, and resting on the skid extensions. Insure that all surfaces are in alignment.. Now, using High Stick Masking Tape, hold the modules firmly together on all sides. Continue the drilling process per Photos #3 & 4. Repeat the process for the Forward Module. Clean the entry of the holes, inside and out.

Use 3/8"-16 UNC Hex Head Bolts, about 3-1/2" long, for fastening the 3 Modules together. Stainless Steel preferred, but expensive. Also use heavy duty washers (thick), 1-1/2" outside diameter minimum, under Bolt head and Nut.

A 3/8-16 Wing Nut is acceptable, as long as you can tighten it by hand sufficiently . Otherwise use a Hex Nut and fasten with a wrench.

A Nylock Nut is even better, as it will not vibrate loose.

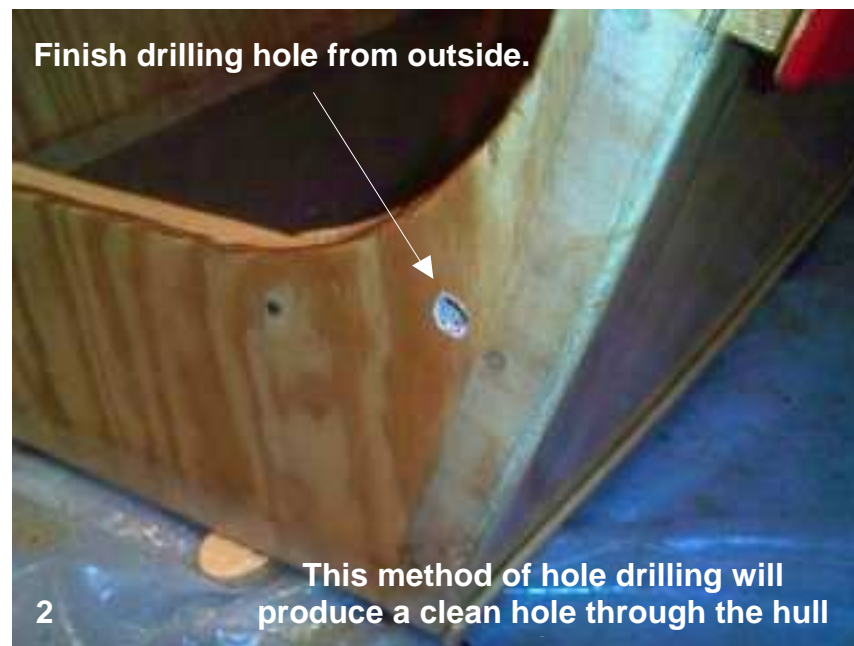

This is not photos of the Modular PDRacer. It is a similar boat, built in a similar fashion.

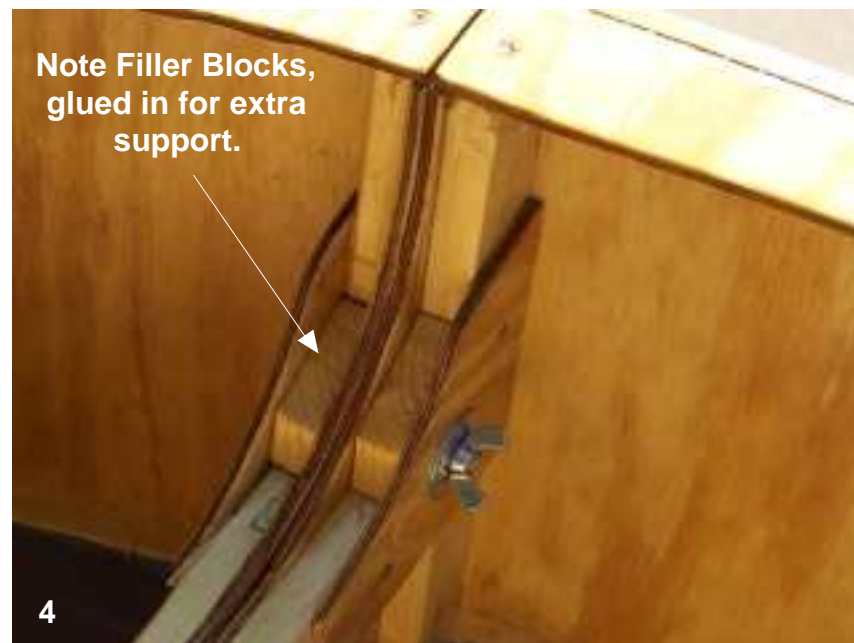
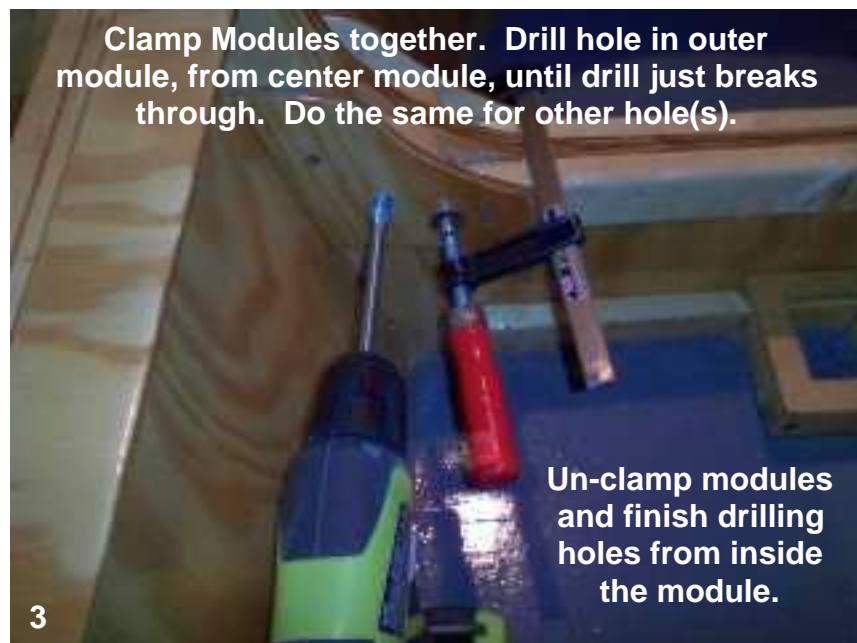



SEALING and FINISHING

Now is the time, if you have not already done so, to treat the entire hull, inside and outside, with **Thompsons Water Seal**. This is done to prevent the plywood from absorbing moisture. It is important you follow the Manufacturers Instructions for application and drying time. When complete, and after drying, you must lightly sand all treated surfaces of the hull. I usually use 150-180 grit for this operation. Sanding helps the adhesion of the surface finish being applied next. Other materials can be used for this purpose; exterior primer, marine paint, exterior enamel or varnish, the choice is yours.

Finally, apply the finish of choice to the hull surfaces. Select a finish that is at least water resistant (non-porous). I generally use Marine Spar Varnish, primarily because it seals the wood so well, but also because it make a wood boat look so good.

You should check exterior surfaces after each use for any water penetration, such as surface checking (roughness) or lifting of the finish. Repair as necessary. Constant maintenance will vastly extend the usefulness, safety and life of your boat.

This boat, like all PDRacers, requires special attention when it comes to a color scheme. These boats attract a lot of attention, and bright and decorative colors just add to their mystique.

Good luck with your build, and subsequent sailing. Be sure to join the PDRacer Club to learn what's new, and to hear about the races and gatherings of PDRacer builders in your neck of the woods.

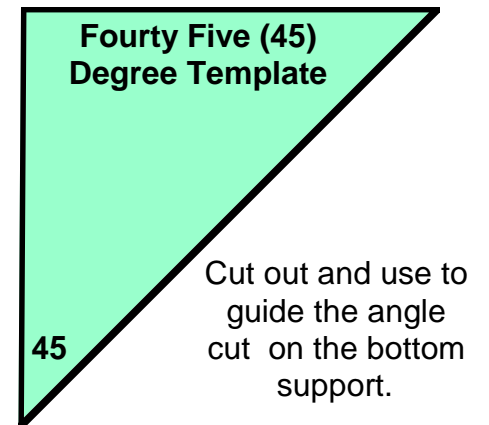
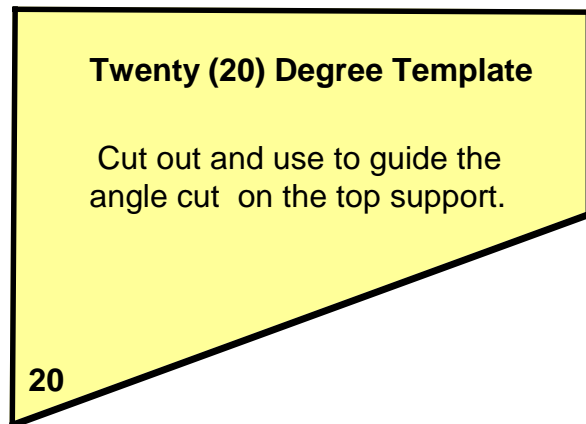
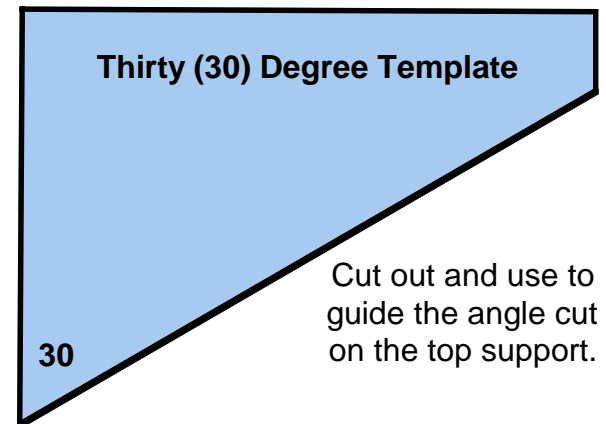
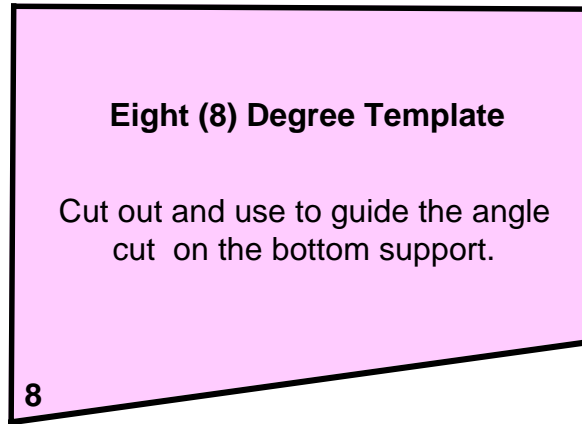

MODULAR PDRacer

OPTIONAL MOTOR

Glue and screw the motor mount spacers to the Transom, as shown. Add the 1/2" ply full face plate. This design is compatible with an external rudder mount, and adds rigidity to the transom.

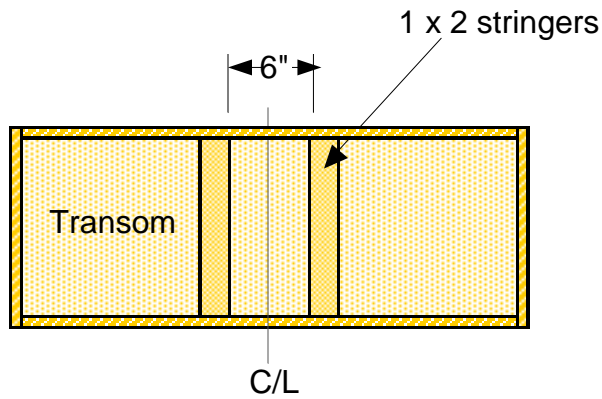

The rectangle developed slot will fit the motor plate, which is 3/4" plywood. Some fitting, and sanding of the plate, will be necessary.

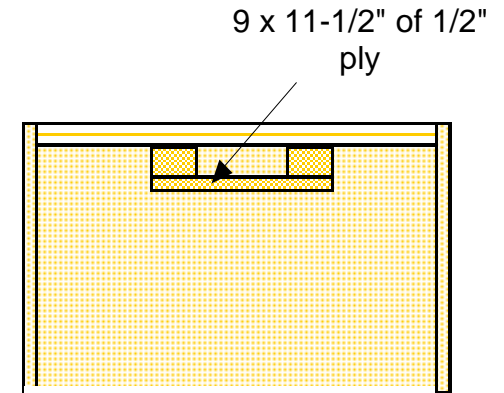
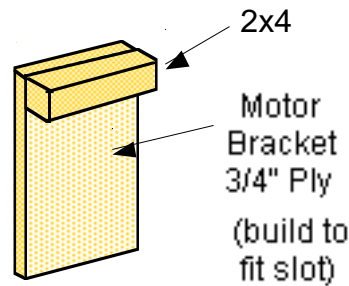

These are photos of other boats of similar size and type, built in a similar fashion.

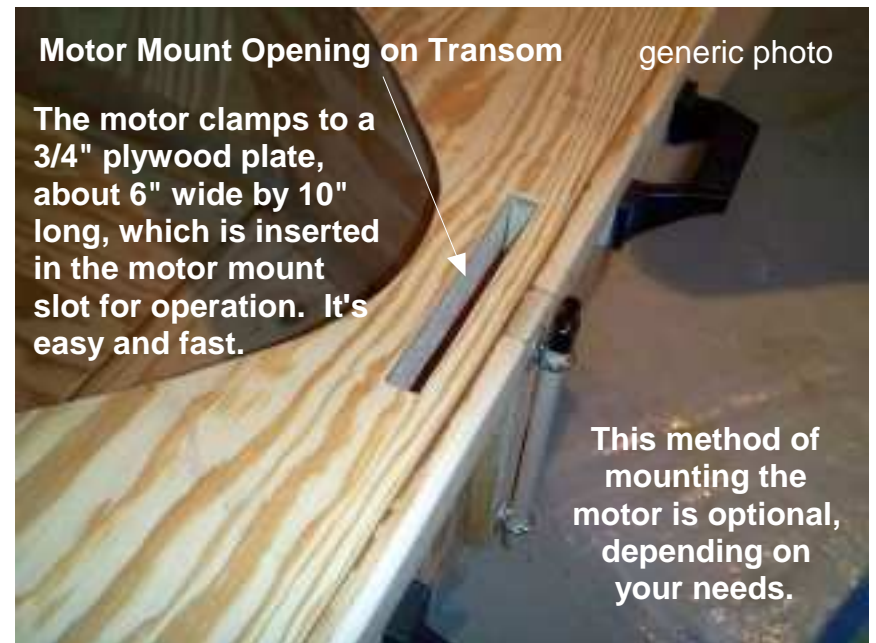
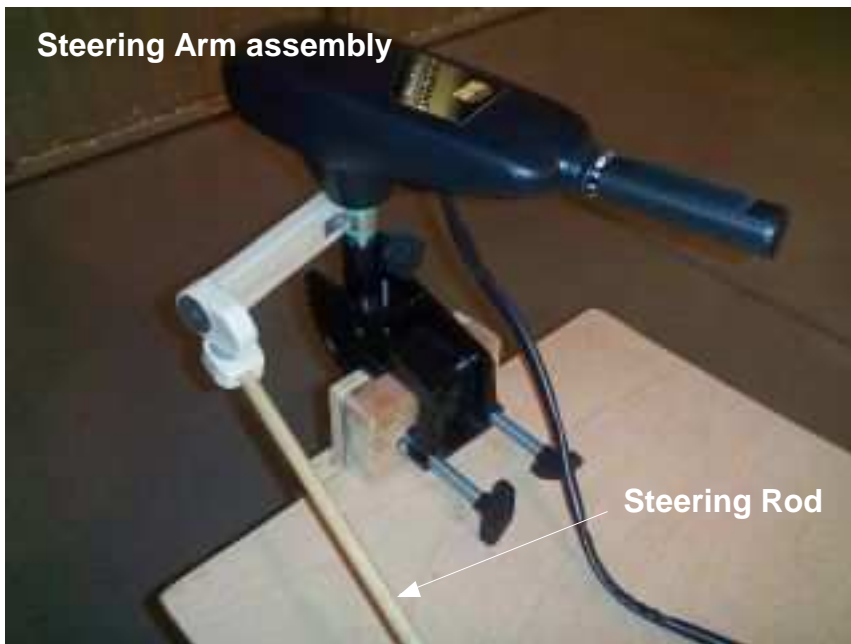

**OPTIONAL
RUDDER ASSEMBLY**

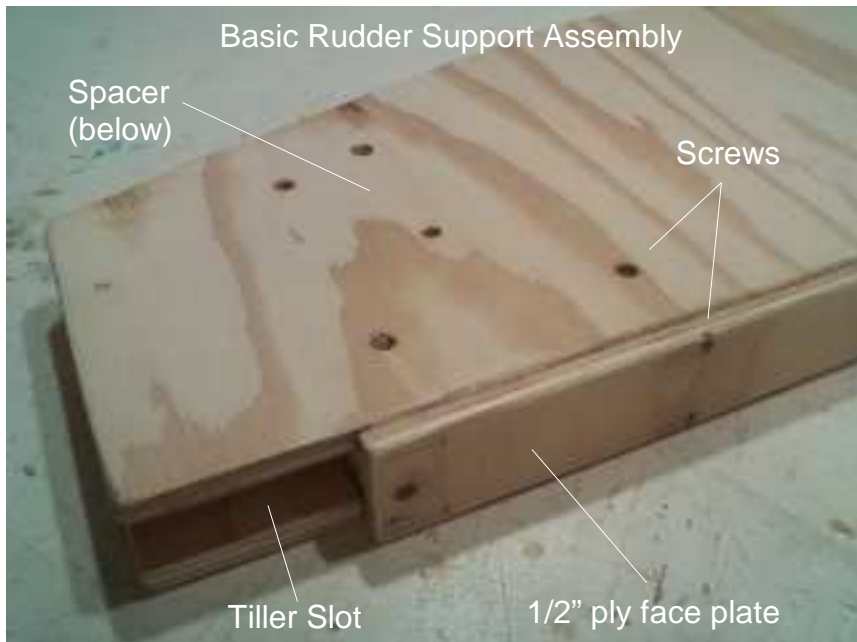
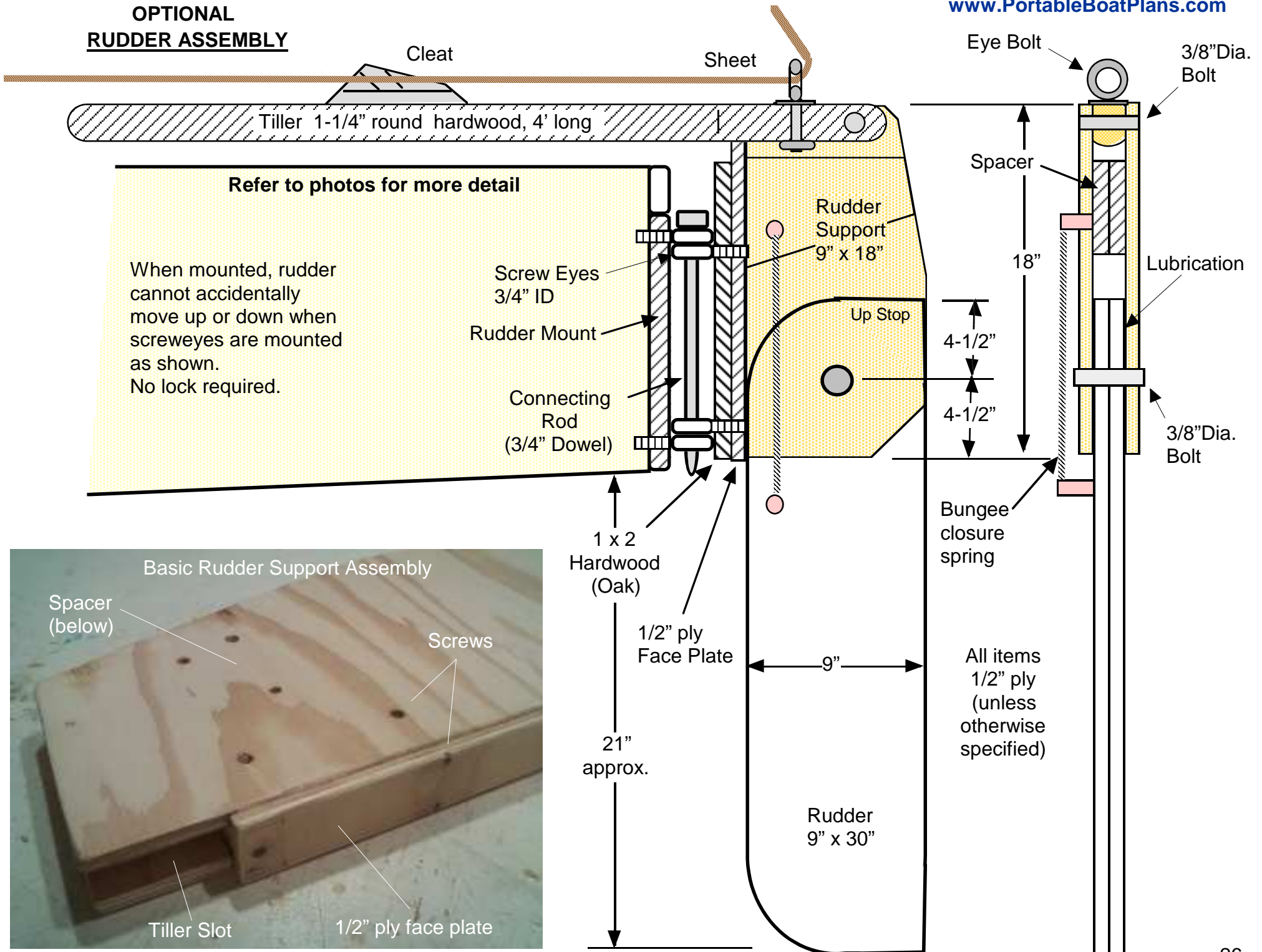

OPTIONAL RUDDER MOUNT & ASSEMBLY

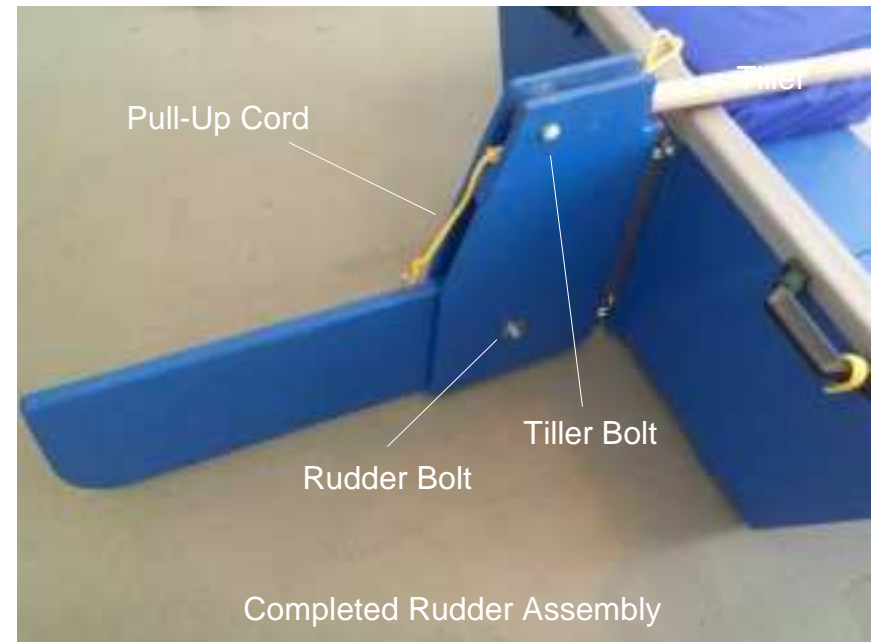
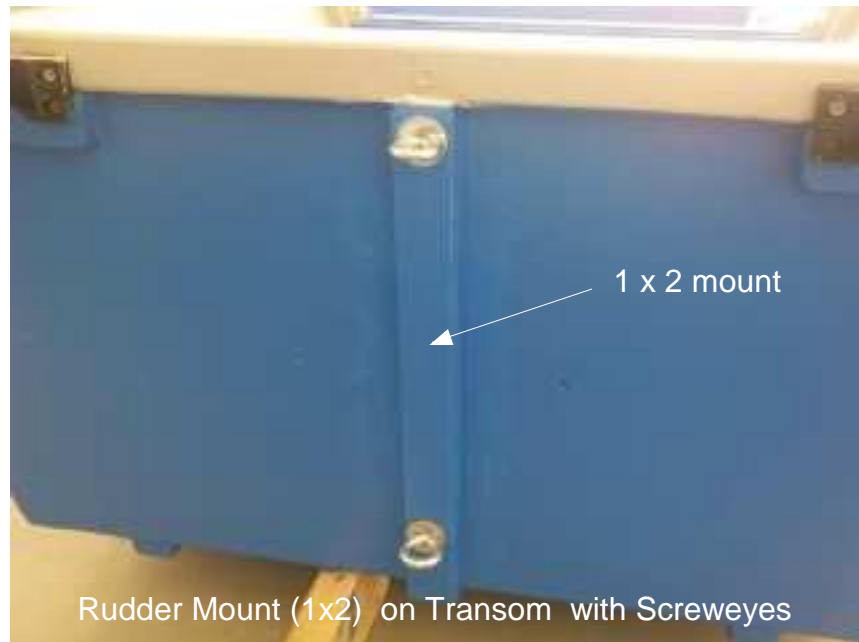
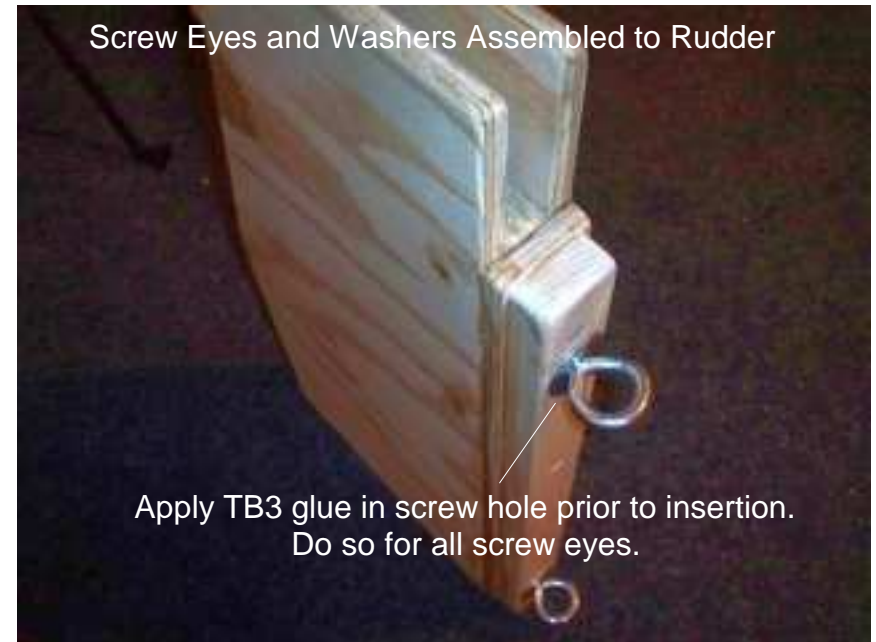

OPTIONAL ROPE STEERING

This is a simple, yet effective method of controlling the rudder. The rope is 3/8 dia. general purpose nylon. For best results, pulleys should be used at the 4 corners the rope has to negotiate. By simply pulling or pushing the rope with either hand, the rudder is easily turned.

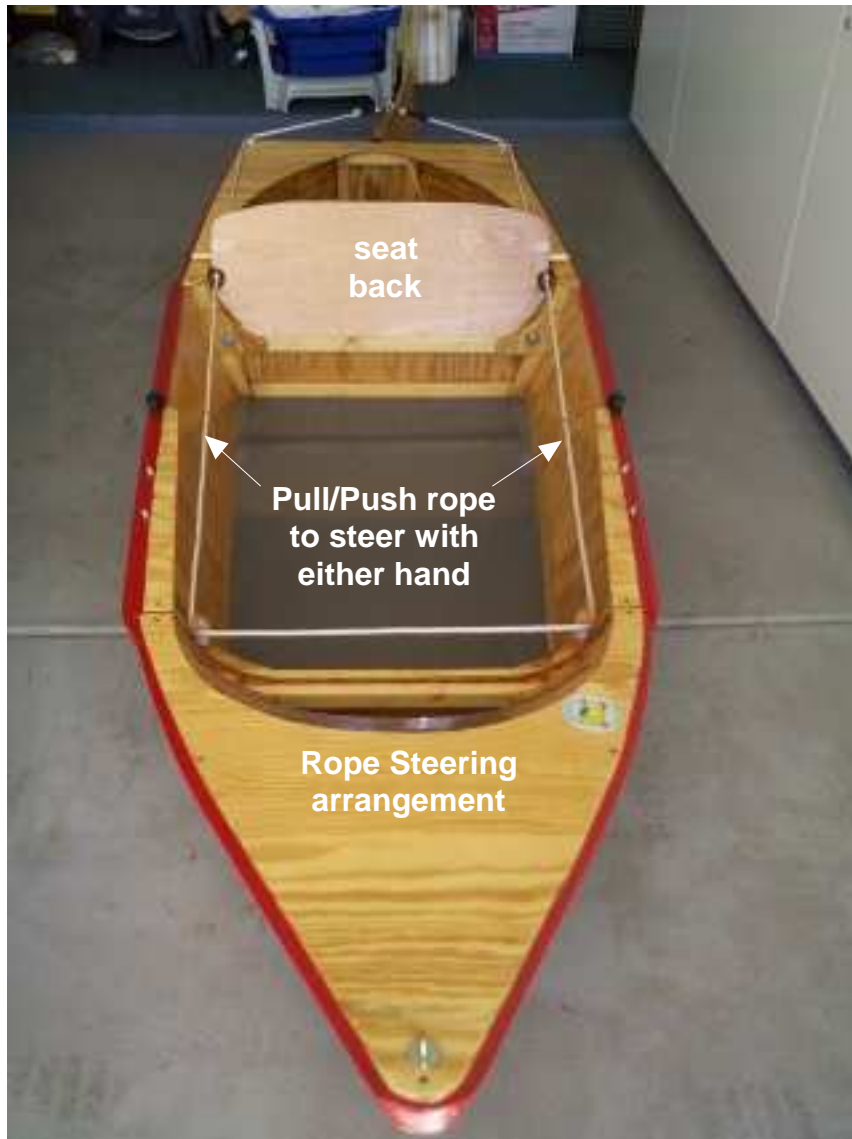

This is not the Modular PDRacer, but a similar size boat, built in a similar fashion.

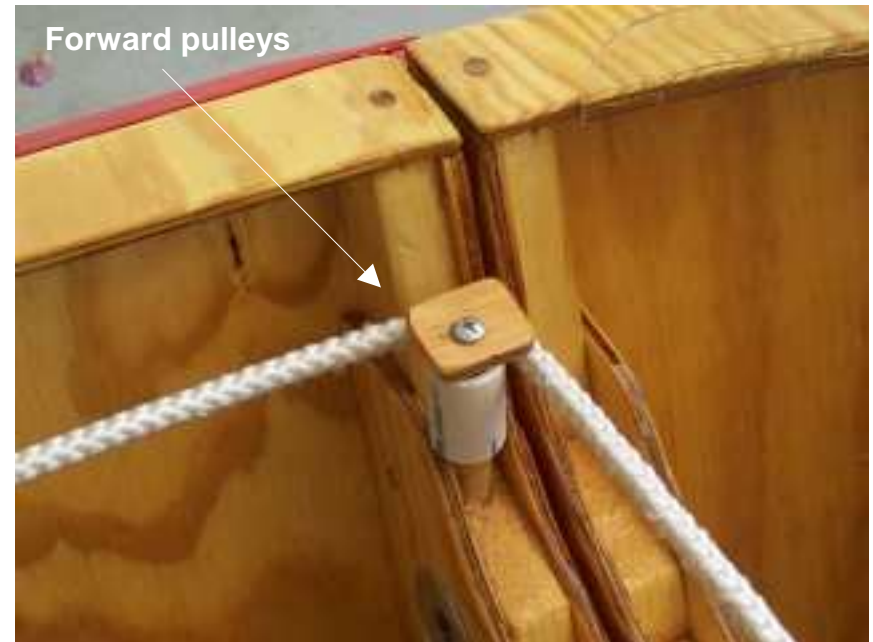

Pulleys can be home made or purchased. Locate pulleys so that they do not interfere with the operator or the function of the Mast or Halyards.

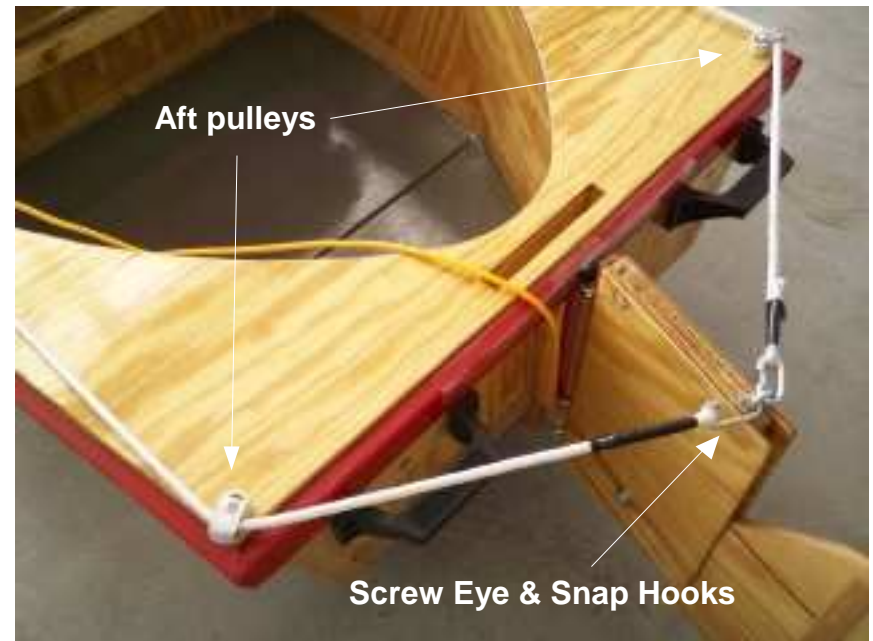

45 degree stops need to be applied.

The following small boat assembly process was developed out of the need for an easy, lightweight, cost effective and health friendly method of providing a structurally sound and sealed small hull assembly. Let it be said up front that it is not the solution to everyones needs. In fact, to do it right, the boat should be designed with this process in mind.

Basically, 'Tape & Glue' is a method for sealing and strengthening all seams of a small boat to the elements. It is not unlike Stitch & Glue, except it is not used to actually construct the boat. 'T&G' (as it will be referred to) is applied after the boat is fully assembled, minus a few appendages, such as skids and rubrails. For this reason alone, it is best if the boat is designed to utilize the 'T&G' process. It should also be stated that the outer seams are naturally subject to damage from rocks and beaching the boat, so protective skids or rails at or near the joint are strongly recommended. The 'Tape & Glue' process has been used on boats such as an eleven foot Canoe, a nine foot pram, an eight foot rowboat and a 10 foot sailboat. Each of these applications used the same materials and process, and all have performed safely.

To best take advantage of 'T & G', the hull design should be capable of being constructed by gluing and screwing the various parts together, to make a self-supporting structure. Additionally, the base panels, and any decking, should always overlap the side panels and end bulkheads. This means the various hull elements should fit together in such a way that heavy structural elements (stringers, gussets and forms) will be minimized, reducing hull weight while maintaining hull strength and integrity.

Then, Taping and Gluing the various inside and outside hull seams with *glue impregnated fiberglass cloth tape* will add the necessary structural bond and joint sealing that will complete the build cycle. This is a relatively easy process. It does not use toxic materials, and cleans up with water prior to curing.

If you have question regarding this process, email me and I will respond promptly to your input.

kensimpsonaz@yahoo.com

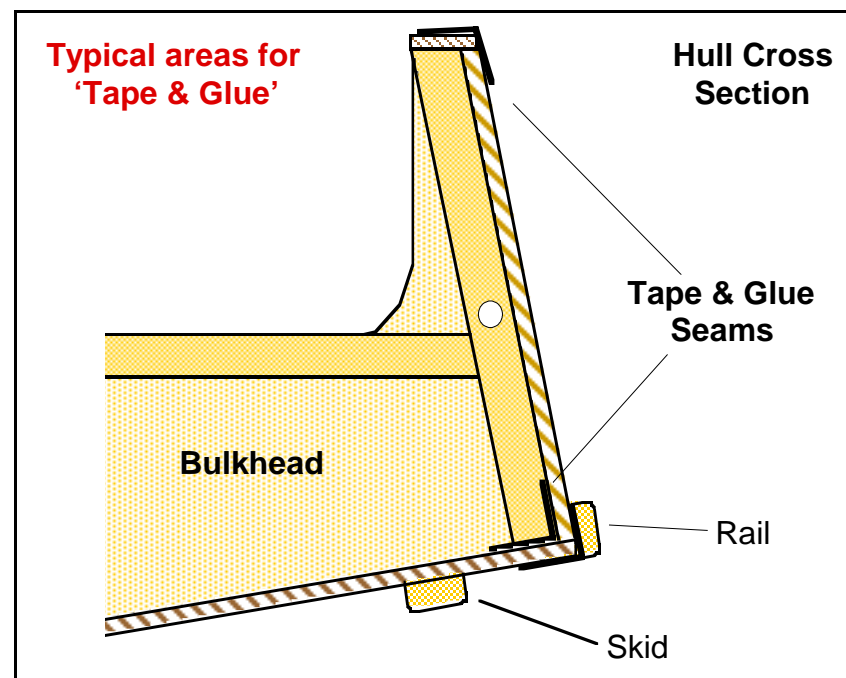

www.PortableBoatPlans.com

1 of 4 pages

[print in landscape mode](#)

Go to: www.PortableBoatPlans.com for the latest version of this process. Download is FREE.



Offset Mast with Leeboard



Open Construction with Expanded Sail Area



Folding Mast



Extra wide hull, twin sails !

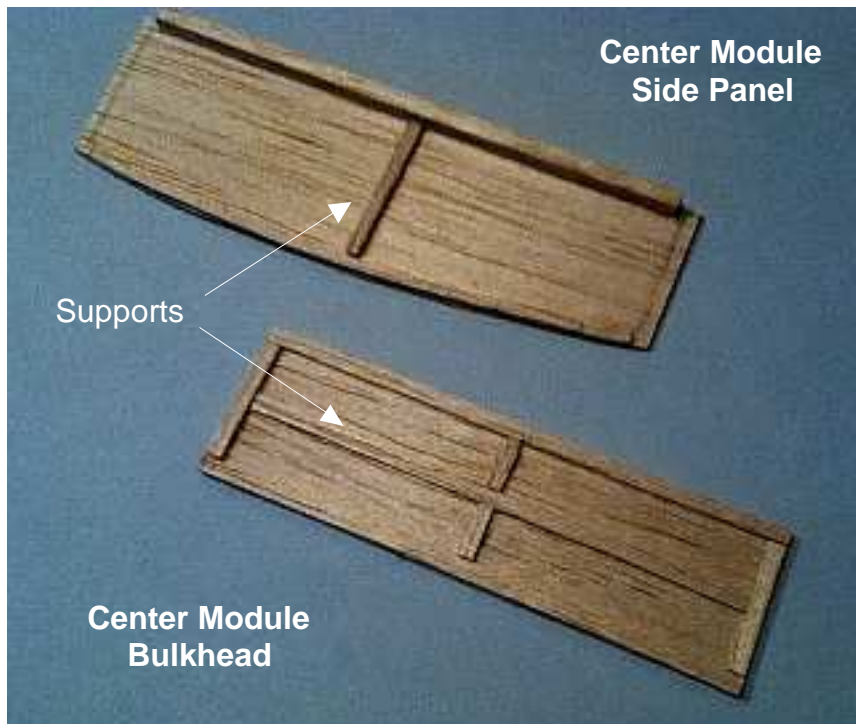

MODULAR PDRacer

MODEL

www.PortableBoatPlans.com



These pictures of the model help clarify the 3 Module concept. As you can see, the Center Module easily holds the two others, with room left over for storage of sailing gear, such as the rigging, sails and the rudder.

The photos also illustrate the spaciousness of the cabin, and the storage areas fore and aft.



The model scale is 1" = 1'



The End